

TURCK

Industrial
Automation

BL20 -

**USER MANUAL
FOR
EtherNet/IP**

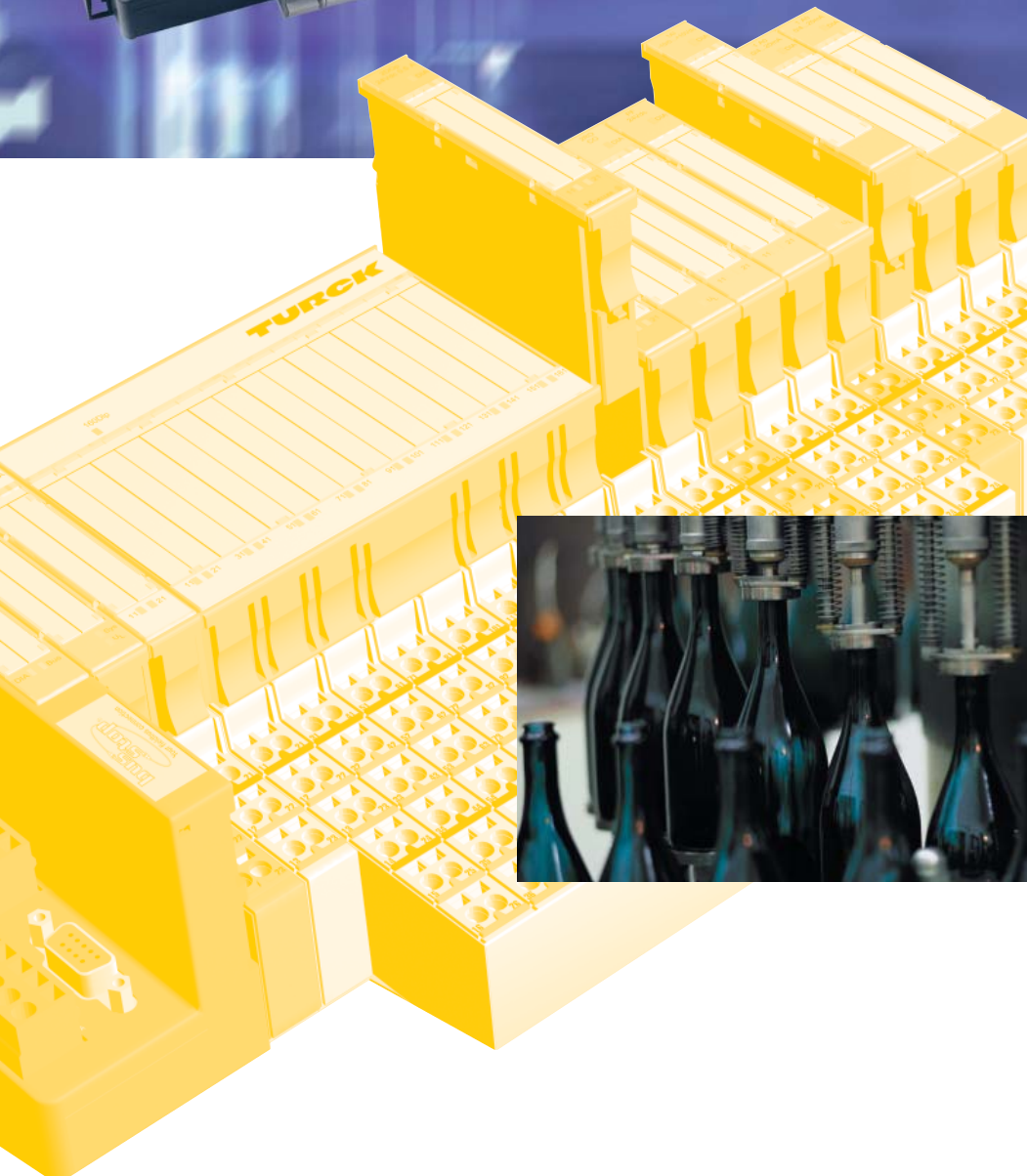

All brand and product names are trademarks or registered trade marks of the owner concerned.

Edition 12/2011

© Hans Turck GmbH, Muelheim an der Ruhr

All rights reserved, including those of the translation.

No part of this manual may be reproduced in any form (printed, photocopy, microfilm or any other process) or processed, duplicated or distributed by means of electronic systems without written permission of Hans Turck GmbH & Co. KG, Muelheim an der Ruhr.

Subject to alterations without notice

Warning!

Before commencing the installation

- Disconnect the power supply of the device.
- Ensure that devices cannot be accidentally restarted.
- Verify isolation from the supply.
- Earth and short circuit.
- Cover or enclose neighboring units that are live.
- Follow the engineering instructions of the device concerned.
- Only suitably qualified personnel in accordance with EN 50 110-1/-2 (VDE 0 105 Part 100) may work on this device/system.
- Before installation and before touching the device ensure that you are free of electrostatic charge.
- The functional earth (FE) must be connected to the protective earth (PE) or to the potential equalization. The system installer is responsible for implementing this connection.
- Connecting cables and signal lines should be installed so that inductive or capacitive interference do not impair the automation functions.
- Install automation devices and related operating elements in such a way that they are well protected against unintentional operation.
- Suitable safety hardware and software measures should be implemented for the I/O interface so that a line or wire breakage on the signal side does not result in undefined states in the automation devices.
- Ensure a reliable electrical isolation of the low voltage for the 24 volt supply. Only use power supply units complying with IEC 60 364-4-41 (VDE 0 100 Part 410) or HD 384.4.41 S2.
- Deviations of the mains voltage from the rated value must not exceed the tolerance limits given in the specifications, otherwise this may cause malfunction and dangerous operation.
- Emergency stop devices complying with IEC/EN 60 204-1 must be effective in all operating modes of the automation devices. Unlatching the emergency-stop devices must not cause restart.
- Devices that are designed for mounting in housings or control cabinets must only be operated and controlled after they have been installed with the housing closed. Desktop or portable units must only be operated and controlled in enclosed housings.
- Measures should be taken to ensure the proper restart of programs interrupted after a voltage dip or failure. This should not cause dangerous operating states even for a short time. If necessary, emergency-stop devices should be implemented.
- Wherever faults in the automation system may cause damage to persons or property, external measures must be implemented to ensure a safe operating state in the event of a fault or malfunction (for example, by means of separate limit switches, mechanical interlocks etc.).
- The electrical installation must be carried out in accordance with the relevant regulations (e. g. with regard to cable cross sections, fuses, PE).
- All work relating to transport, installation, commissioning and maintenance must only be carried out by qualified personnel. (IEC 60 364 and HD 384 and national work safety regulations).
- All shrouds and doors must be kept closed during operation.

Table of contents

1	About this manual	
1.1	Documentation concept	1-2
1.2	General information.....	1-3
1.2.1	Prescribed use	1-3
1.2.2	Notes concerning planning /installation of this product	1-3
1.3	Description of symbols used	1-4
1.4	List of revisions	1-5
2	BL20 philosophy	
2.1	The basic concept	2-2
2.1.1	Flexibility	2-2
2.1.2	Convenient handling	2-2
2.2	BL20 components.....	2-3
2.2.1	Gateways	2-3
2.2.2	Power distribution modules.....	2-3
2.2.3	Electronics modules	2-3
2.2.4	Base modules.....	2-5
2.2.5	BL20 Economy.....	2-6
2.2.6	End plate.....	2-6
2.2.7	End bracket.....	2-7
2.2.8	Jumpers.....	2-7
2.2.9	Marking material.....	2-7
2.2.10	Shield connection, 2-pole for analog modules	2-9
3	EtherNet/IP	
3.1	System description	3-2
3.1.1	Network-topology.....	3-3
3.1.2	Addressing on EtherNet/IP	3-4
3.1.3	Network classes.....	3-4
3.1.4	Checking the communication via "ping-signals".....	3-5
3.1.5	ARP (Address Resolution Protocol)	3-5
4	Technical features	
4.1	General	4-2
4.2	Function	4-3
4.3	Technical data.....	4-4
4.3.1	Gateway structure.....	4-4
4.4	Connection possibilities.....	4-6
4.4.1	Field bus connection.....	4-6
4.4.2	Power Supply via terminal block with screw connection.....	4-6
4.4.3	Service interface connection (female PS/2 connector)	4-6
4.5	Address setting.....	4-8
4.5.1	LED-behavior	4-8
4.5.2	Default setting of the gateway.....	4-9

4.5.3	Address setting via the rotary-mode	4-9
4.5.4	Address setting via BootP-mode.....	4-10
4.5.5	Address setting via DHCP-mode	4-11
4.5.6	Address setting via PGM-mode	4-12
4.5.7	Address setting via PGM-DHCP	4-13
4.5.8	Address-setting via I/O-ASSISTANT 3 (FDT/DTM)	4-14
4.6	SET button	4-17
4.7	Status indicators/diagnostic messages gateway	4-18
4.7.1	Diagnostic messages via LEDs	4-18
4.7.2	Diagnostic messages via the process data	4-21
4.8	Status and Control word of the gateway	4-23
4.8.1	Status word	4-23
4.8.2	Control word	4-23
4.9	Module specific diagnostic messages	4-24
5	Implementation of EtherNet/IP	
5.1	The EtherNet/IP Communications Profile	5-3
5.1.1	I/O Messages	5-3
5.1.2	Explicit Messages	5-3
5.1.3	Communications profile of the BL20 EtherNet/IP gateway	5-3
5.2	Classes and instances of the EtherNet/IP-gateway	5-5
5.2.1	EtherNet/IP Standard Classes	5-5
5.2.2	Identity Object (0x01)	5-6
5.2.3	Message Router Object (0x02)	5-8
5.2.4	Assembly Object	5-13
5.2.5	Connection Manager Object (0x06)	5-17
5.2.6	Port Object (0xF4)	5-17
5.2.7	TCP/IP Interface Object (0xF5).....	5-18
5.2.8	Ethernet Link Object (0xF6).....	5-23
5.3	VSC-Vendor Specific Classes	5-25
5.3.1	Class Instance of the VSC	5-26
5.3.2	Gateway Class (VSC 100)	5-27
5.3.3	Terminal Slot Class (VSC 101)	5-30
5.3.4	Process Data Class (VSC102)	5-32
5.3.5	Power Supply Module Class (VSC103).....	5-34
5.3.6	Digital Input Module Class (VSC104)	5-36
5.3.7	Digital Output Module Class (VSC105).....	5-38
5.3.8	Analog Input Voltage Module Class (VSC106).....	5-40
5.3.9	Analog Output Voltage Module Class (VSC107).....	5-42
5.3.10	Analog Input Current Module Class (VSC108).....	5-44
5.3.11	Analog Output Current Module Class (VSC109).....	5-46
5.3.12	Analog Input PT100/NI Module Class (VSC110).....	5-48
5.3.13	Analog Input THERMO Module Class (VSC111)	5-51
5.3.14	Counter Module Class (VSC112)	5-54
5.3.15	RS232 Module Class (VSC114).....	5-60
5.3.16	RS485/422 Module Class (VSC115).....	5-67
5.3.17	SSI Module Class (VSC116).....	5-74
5.3.18	Digital Versatile Module Class (VSC117).....	5-82
5.3.19	Analog Versatile Module Class (VSC118).....	5-86

5.3.20	SWIRE module class (VSC121)	5-89
5.3.21	RFID-S module class (VSC124)	5-94
6	Application example: BL20 gateway with an Allen Bradley PLC	
6.1	General	6-2
6.1.1	Prerequisites for this example	6-2
6.2	Network configuration.....	6-3
6.3	Changing the IP address of a PC/ network interface card	6-4
6.3.1	Changing the IP address in Windows 2000/ Windows XP	6-4
6.3.2	Changing the IP address in Windows NT	6-5
6.3.3	Changing the IP address via I/O-ASSISTANT V3	6-6
6.4	Address setting at the gateway.....	6-10
6.4.1	Address setting via DHCP-mode	6-10
6.5	Setting-up communications with the software tool "RSLinx"	6-13
6.6	Configuration of the network in "RSLogix 5000"	6-14
6.6.1	Configuration of the controller	6-14
6.6.2	Configuration of a BL20 station	6-16
6.6.3	Downloading the I/O configuration	6-18
6.7	Examples for I/O data mapping.....	6-20
6.7.1	Mapping report via I/O-ASSISTANT	6-22
6.8	Example for process data access	6-23
6.8.1	Setting outputs at BL20-2DO-0.5A-P	6-23
7	Guidelines for station planning	
7.1	Random module arrangement	7-2
7.1.1	Complete planning.....	7-2
7.1.2	Maximum system extension	7-2
7.2	Power supply	7-4
7.2.1	Module bus refreshing	7-4
7.2.2	Creating potential groups.....	7-7
7.2.3	Protecting the service interface on the gateway.....	7-8
7.2.4	C-Rail (cross connection)	7-8
7.2.5	Direct wiring of relay modules	7-10
7.3	Plugging and pulling electronics modules.....	7-11
7.4	Extending an existing station.....	7-12
7.5	Firmware download	7-13
8	Guidelines for electrical installation	
8.1	General notes.....	8-2
8.1.1	General.....	8-2
8.1.2	Cable routing	8-2
8.1.3	Cable routing inside and outside of cabinets	8-2
8.1.4	Lightning protection.....	8-3
8.1.5	Transmission media.....	8-4

8.2	Potential relationships	8-5
8.2.1	General	8-5
8.3	Electromagnetic Compatibility (EMC)	8-6
8.3.1	Ensuring EMC	8-6
8.3.2	Grounding of inactive metal components	8-6
8.3.3	PE connection	8-6
8.3.4	Earth-free operation	8-6
8.3.5	Mounting rails	8-7
8.4	Shielding of cables	8-8
8.5	Potential compensation	8-9
8.5.1	Switching inductive loads	8-9
8.5.2	Protection against Electrostatic Discharge (ESD)	8-9
9	BL20-Approvals for Zone 2/ Division 2	
10	Appendix	
10.1	Data image of the technology modules	10-2
10.1.1	Counter module	10-2
10.1.2	RSxxx-module	10-13
10.1.3	SSI-module	10-17
10.2	Nominal current consumption and power loss	10-22
10.3	Power loss of the modules	10-26
11	Glossary	
12	Index	

1 About this manual

1.1	Documentation concept	2
1.2	General information	3
1.2.1	Prescribed use	3
1.2.2	Notes concerning planning /installation of this product	3
1.3	Description of symbols used	4
1.4	List of revisions	5

1.1 Documentation concept

This manual contains information about the BL20 Ethernet gateway with EtherNet/IP.

The following chapters contain a short BL20 system description, a description of the field bus system Ethernet, exact information about function and structure of the BL20 Ethernet gateways as well as all bus specific information concerning the connection to automation devices, the maximum system extension etc..

The bus-independent I/O-modules for BL20 as well as all further fieldbus-independent chapters like mounting, labelling etc. are described in a separate manual.

- BL20 I/O-modules
(TURCK-Dokumentation-No.: German D300716/ English D300717)

Furthermore, the manual mentioned above contains a short description of the project planning and diagnostics software for TURCK I/O-systems, the engineering software I/O-ASSISTANT.

1.2 General information



Attention

Please read this section carefully. Safety aspects cannot be left to chance when dealing with electrical equipment.

This manual contains all necessary information about the prescribed use of the TURCK BL20 gateways for Ethernet.

It has been specially conceived for personnel with the necessary qualifications.

1.2.1 Prescribed use



Danger

The devices described in this manual must be used only in applications prescribed in this manual or in the respective technical descriptions, and only with certified components and devices from third party manufacturers.

Appropriate transport, storage, deployment and mounting as well as careful operating and thorough maintenance guarantee the trouble-free and safe operation of these devices.

1.2.2 Notes concerning planning /installation of this product



Danger

All respective safety measures and accident protection guidelines must be considered carefully and without exception.

1.3 Description of symbols used



Danger

This sign can be found next to all notes that indicate a source of hazards. This can refer to danger to personnel or damage to the system (hardware and software) and to the facility. This sign means for the operator: work with extreme caution.

Attention

This sign can be found next to all notes that indicate a potential hazard. This can refer to possible danger to personnel and damages to the system (hardware and software) and to the facility.



Note

This sign can be found next to all general notes that supply important information about one or more operating steps. These specific notes are intended to make operation easier and avoid unnecessary work due to incorrect operation.

1.4 List of revisions

In comparison to the previous manual edition, the following changes/ revisions have been made:

*Table 1-1:
List of revisions*

Chapter	Subject/ Description	new	changed/ updated
4	Address-setting via I/O-ASSISTANT 3 (FDT/DTM)		X
9	BL20-Approvals for Zone 2/ Division 2 → separate manual D301255		X
10	Appendix	X	

**Note**

The publication of this manual renders all previous editions invalid.

About this manual

2 BL20 philosophy

2.1	The basic concept	2
2.1.1	Flexibility	2
2.1.2	Convenient handling	2
2.2	BL20 components.....	3
2.2.1	Gateways	3
2.2.2	Power distribution modules.....	3
2.2.3	Electronics modules	3
2.2.4	Base modules.....	5
2.2.5	BL20 Economy.....	6
2.2.6	End plate.....	6
2.2.7	End bracket.....	7
2.2.8	Jumpers	7
2.2.9	Marking material	7
2.2.10	Shield connection, 2-pole for analog modules	9

2.1 The basic concept

BL20 is a modular IP20 I/O-system for use in industrial automation. It connects the sensors and actuators in the field to the higher-level master.

BL20 offers modules for practically all applications:

- Digital input and output modules
- Analog input and output modules
- Technology modules (RS232 interface,...)

A complete BL20 station counts as **one** station on the bus and therefore occupies **one** fieldbus address in any given fieldbus structure. A BL20 station consists of a gateway, power distribution modules and I/O-modules.

The connection to the relevant fieldbus is made via the bus-specific gateway, which is responsible for the communication between the BL20 station and the other fieldbus stations.

The communication within the BL20 station between the gateway and the individual BL20 modules is realized via an internal module bus.



Note

The gateway is the only fieldbus-dependent module on a BL20 station. All other BL20 modules are not dependent on the fieldbus used.

2.1.1 Flexibility

A BL20 station can contain modules in any combination, which means it is possible to adapt the system to practically all applications in automated industries.

2.1.2 Convenient handling

All BL20 modules, with the exception of the gateway, consist of a base module and an electronic module.

The gateway and the base modules are either snapped onto a mounting rail or are directly mounted onto the machine frame. The electronic modules are plugged onto the appropriate base modules.

After disconnection of the load, the electronic modules can be plugged or pulled when the station is being commissioned or for maintenance purposes, without having to disconnect the field wiring from the base modules.

2.2 BL20 components

2.2.1 Gateways

The gateway connects the fieldbus to the I/O-modules. It is responsible for handling the entire process data and generates diagnostic information for the higher-level master and the software tool I/O-ASSISTANT.

Figure 2-1:
BL20 gateway

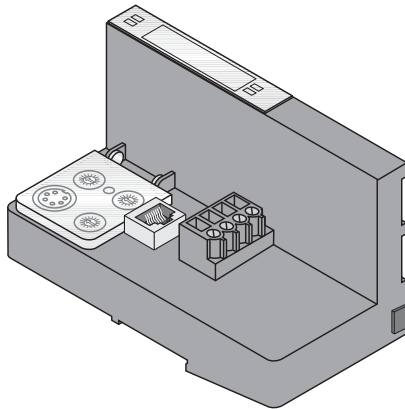

The BL20 gateways BL20-GW-EN offer an integrated power supply unit for feeding the gateway and the connected I/O modules.

It is not necessary to supply each individual module with a separate voltage.

2.2.2 Power distribution modules

The power supply for gateways and I/O modules is fed to the power distribution modules; therefore, it is not necessary to supply each individual module with a separate voltage.

Figure 2-2:
Power distribu-
tion module

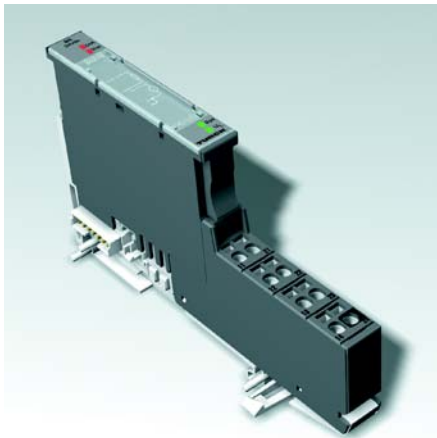

2.2.3 Electronics modules

Electronics modules contain the functions of the BL20 modules (power distribution modules, digital and analog input/output modules, and technology modules).

Electronics modules are plugged onto the base modules and are not directly connected to the wiring. The assignment table in the Section "Ordering Information" of the "Appendix" shows the possible

BL20 philosophy

combinations of electronics and base modules. They can be plugged or pulled when the station is being commissioned or for maintenance purposes, without having to disconnect the field wiring from the base modules.

*Figure 2-3:
Electronics
module in slice
design*

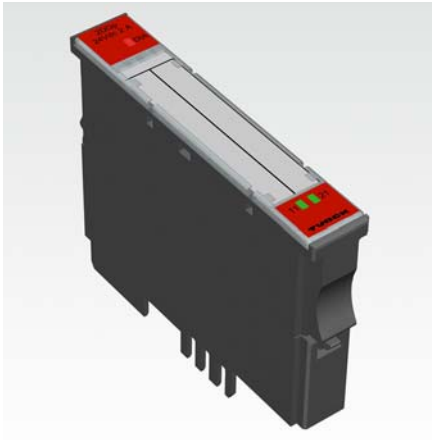

*Figure 2-4:
Electronics
module in block
design*

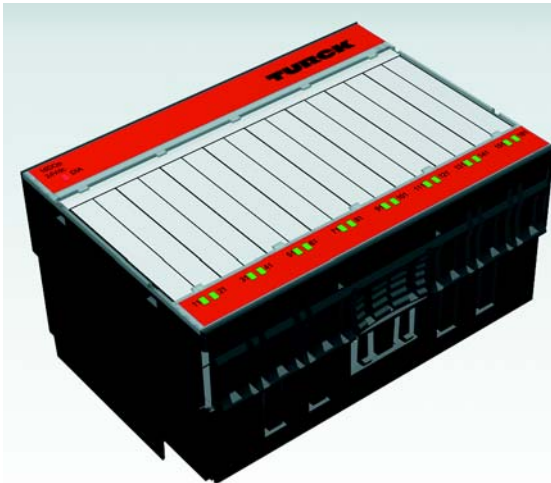

2.2.4 Base modules

The field wiring is connected to the base modules. These are constructed as terminals in block and slice designs and are available in the following variations with either tension clamp or screw connections: 2-/3-wire (2-channel), 4-wire (2-channel) and 4 x 2-/3-wire (4-channel).

The assignment table in the Section "Ordering Information" of the "Appendix" shows the possible combinations of electronics and base modules.

*Figure 2-5:
Base module
with tension
clamp connection*

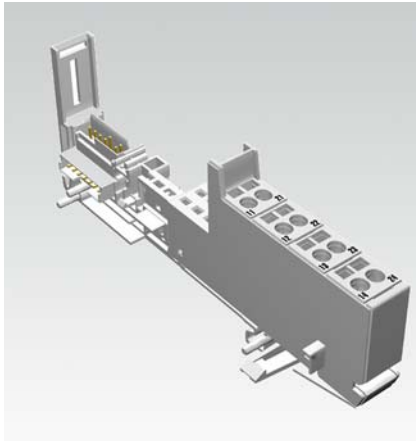

*Figure 2-6:
Base module
with screw connection*

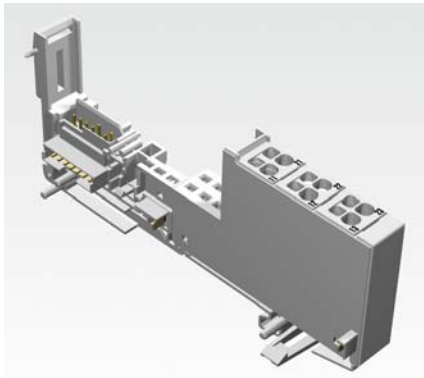

*Figure 2-7:
Base module in
block design*

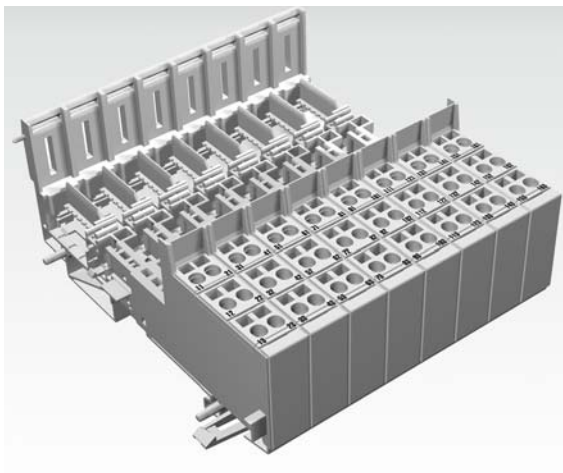

BL20 philosophy

2.2.5 BL20 Economy

With the BL20 Economy modules the electronics and connection technology is integrated into a single housing. Thus, the selection of a base module is unnecessary. Within a station the Economy modules can be combined with the modules with separate electronics/connection technology, provided that the base modules feature tension spring connections.

Figure 2-8:
BL20 Economy

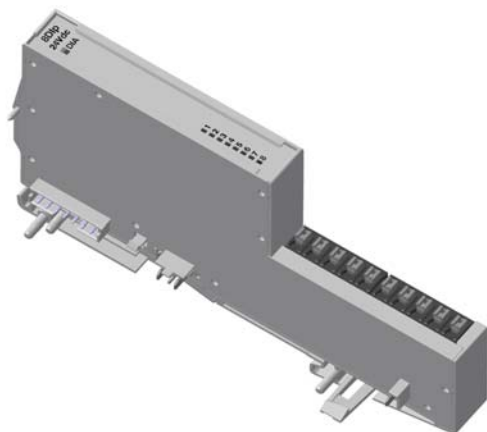

2.2.6 End plate

An end plate on the right-hand side physically completes the BL20 station. An end bracket mounted into the end plate ensures that the BL20 station remains secure on the mounting rail even when subjected to vibration.

Figure 2-9:
End plate

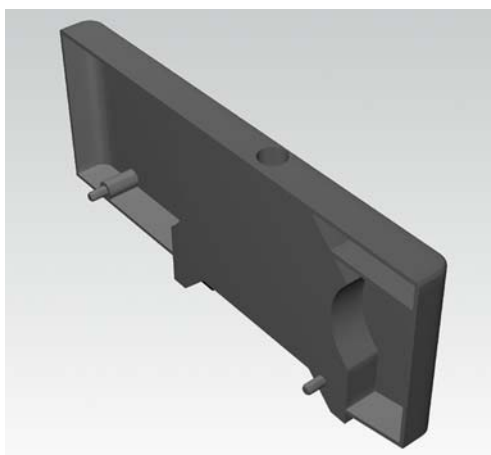

2.2.7 End bracket

A second end bracket to the left of the gateway is necessary, as well as the one mounted into the end plate to secure the station.

Figure 2-10:
End bracket

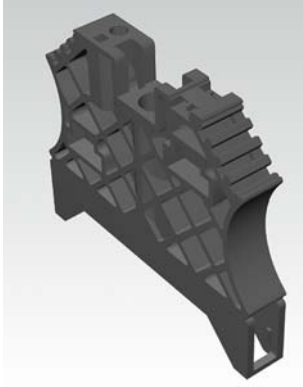

2.2.8 Jumpers

Jumpers (QVRs) are used to bridge a connection level of a 4-wire base module. They can be used to connect potentials in relay modules (bridging the relay roots); thus considerably reducing the amount of wiring.

Figure 2-11:
Jumpers

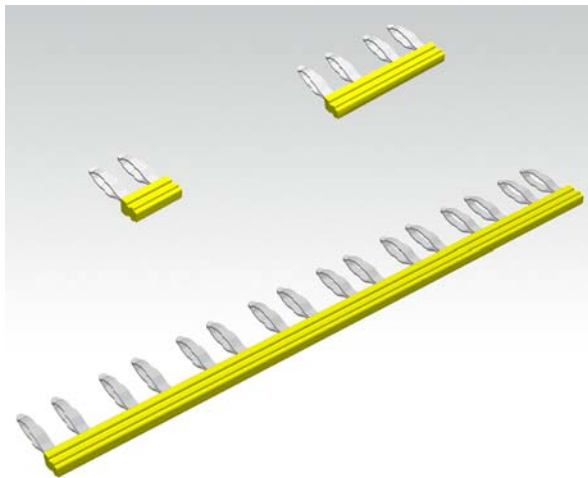

2.2.9 Marking material

- Labels: for labeling BL20 electronics modules.
- Markers: for colored identification of connection levels of BL20 base modules.

BL20 philosophy

- Dekafix connector markers: for numbering the mounting slots on BL20 base modules.

Figure 2-12:
Marking material

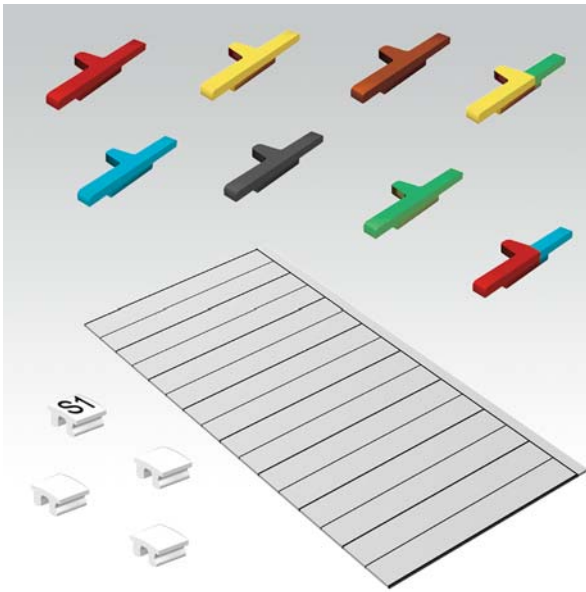

2.2.10 Shield connection, 2-pole for analog modules

The 2-pole shield connection can be used to connect signal-cable shielding to the base modules of analog input and output modules. A special tension-clamp operating tool (BL20-ZBW5-2) is required to mount the shield connection onto the base module.

Figure 2-13:
Shield connection

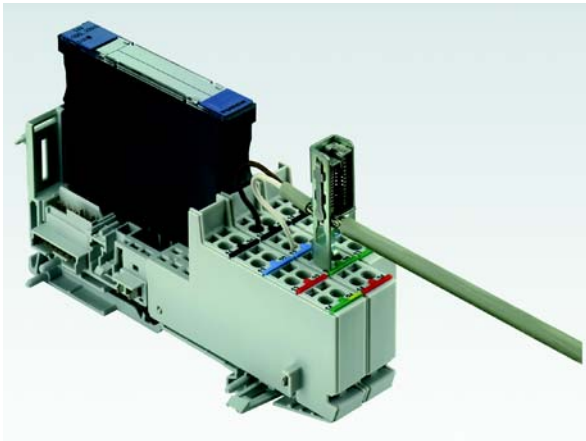

3 EtherNet/IP

3.1	System description	2
	– IP (Internet Protocol).....	3
	– TCP (Transmission Control Protocol)	3
3.1.1	Network-topology	3
	– Transmission media	3
3.1.2	Addressing on EtherNet/IP	4
	– Ethernet MAC-ID.....	4
	– IP address	4
3.1.3	Network classes	4
3.1.4	Checking the communication via "ping-signals"	5
3.1.5	ARP (Address Resolution Protocol).....	5

3.1 System description

Ethernet Industrial Protocol (EtherNet/IP) is a communication system for industrial applications.



It is used to exchange time-critical application information between industrial devices such as simple I/O devices (sensors/actuators) or even complex control devices (robots, programmable logic controllers, etc.).

EtherNet/IP is an open network because it uses:

- IEEE 802.3 Physical and Data Link standard
- Ethernet TCP/IP protocol suite (Transmission Control Protocol/Internet Protocol), the Ethernet industry standard.
- Common Industrial Protocol (CIP), the protocol that provides real-time I/O messaging and information/peer-to-peer messaging. ControlNet and DeviceNet networks also use CIP.



Note

For further information about CIP and EtherNet/IP, please contact also the user organization ODVA (www.odva.org).

IP (Internet Protocol)

The Internet Protocol is a connection-free transport protocol. Since the protocol does not use acknowledgement messages, telegrams can get lost. Therefore it is not suitable for safe data transfer. The main functions of the internet protocol are the addressing of hosts and the fragmentation of data packages.

TCP (Transmission Control Protocol)

The Transmission Control Protocol (TCP) is a connection-oriented transport protocol and is based on the Internet Protocol. A safe and error-free data transport can be guaranteed by means of certain error diagnostic mechanisms. For example, the acknowledgement and time monitoring of telegrams.

UDP/IP (User Datagram Protocol)

UDP/IP provides the fast, efficient data transport necessary for real-time data exchange. To make EtherNet/IP successful, CIP has been added on top of TCP/UDP/IP to provide a common application layer.

Figure 3-1:
EtherNet/IP in
OSI 7 layer model

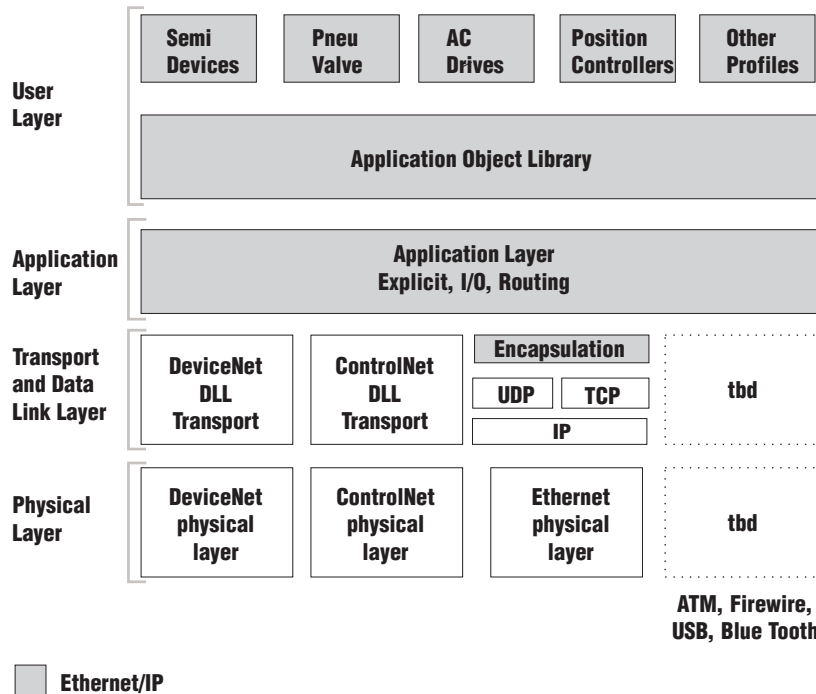

3.1.1 Network-topology

EtherNet/IP network uses an active star topology in which groups of devices are connected point-to-point to a switch.

Products with both transmission speeds (10 and 100 Mbit/s) can be used in the same network and most Ethernet switches will negotiate the speed automatically.

Transmission media

For communication via Ethernet, different transmission media can be used:

- coaxial cable (10Base5)
- optical fibre (10BaseF)
- twisted two-wire cable (10BaseT) with shielding (STP) or without shielding (UTP)

3.1.2 Addressing on EtherNet/IP

Ethernet MAC-ID

The Ethernet MAC-ID is a 6-byte-value which serves to identify an Ethernet device. The MAC-ID is determined for each device by the IEEE (Institute of Electrical and Electronics Engineers, New York).

The first 3 bytes of the MAC-ID contain a manufacturer identifier (Turck: 00:07:46:xx:xx:xx). The last 3 bytes can be chosen freely by the manufacturer for each device and contain a serial number.

The MAC-ID can be read from the module using the software tool "I/O-ASSISTANT".

IP address

Each Ethernet-host receives its own IP address. In addition, the node knows its netmask and the IP address of the default gateway.

The IP address is a 4-byte-value which contains the address of the network to which the node is connected as well as the host address in the network.

The IP address of the BL20-GW-EN-IP gateway is predefined as follows:

```
IP address:      192.168.1.xxx
netmask:        255.255.255.0
gateway:        192.168.1.001
```

The netmask shows which part of the IP address defines the network as well as the network class, and which part of the IP address defines the single node in the network.

In the example mentioned above, the first 3 bytes of the IP address define the network. They contain the subnet-ID 192.168.1.

The last byte of the IP address defines the node's address within the network.



Note

In order to build communication between a PC and an Ethernet-module, both have to be nodes on the same network.

If necessary, the nodes' network addresses have to be adapted one to another. Please read Chapter 5, "Changing the IP address of a PC/ network interface card", Page 5-5.

3.1.3 Network classes

The available networks are divided into the different network classes A, B, and C.

Table 3-1:
Network classes

Class	Network addresses	Bytes for net address	Bytes for host address	No. of possible networks/ hosts
A	1.xxx.xxx.xxx -126.xxx.xxx.xxx	1	3	126/ 2 ²⁴
B	128.0.xxx.xxx -191.255.xxx.xxx	2	2	2 ¹⁴ / 2 ¹⁶
C	192.0.0.xxx - 223.255.255.xxx	3	1	2 ²¹ / 256

According to their predefined address 192.168.1.xxx BL20 gateways are nodes on a Class C network.

3.1.4 Checking the communication via "ping-signals"

You can check the communication between nodes in a network using ping-signals in the DOS-prompt of your PC.

For that purpose, enter the command "ping" and the IP address of the network node to be checked.

If the node answers the ping-signal, it is ready for communication and takes part in the data transfer.

Figure 3-2:
ping-signal

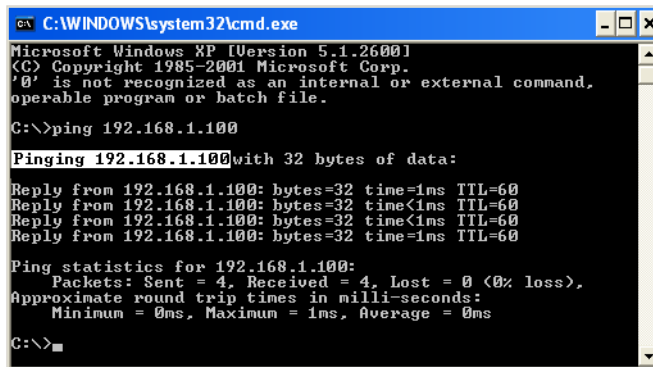

```

C:\WINDOWS\system32\cmd.exe
Microsoft Windows XP [Version 5.1.2600]
(C) Copyright 1985-2001 Microsoft Corp.
'0' is not recognized as an internal or external command,
operable program or batch file.

C:\>ping 192.168.1.100

Pinging 192.168.1.100 with 32 bytes of data:

Reply from 192.168.1.100: bytes=32 time=1ms TTL=60
Reply from 192.168.1.100: bytes=32 time<1ms TTL=60
Reply from 192.168.1.100: bytes=32 time<1ms TTL=60
Reply from 192.168.1.100: bytes=32 time=1ms TTL=60

Ping statistics for 192.168.1.100:
    Packets: Sent = 4, Received = 4, Lost = 0 (0% loss),
    Approximate round trip times in milli-seconds:
        Minimum = 0ms, Maximum = 1ms, Average = 0ms

C:\>

```

3.1.5 ARP (Address Resolution Protocol)

In each TCP/IP-capable computer, ARP serves to clearly assign the worldwide unique hardware addresses (MAC-IDs) to the single IP addresses of the network nodes via internal tables.

Using ARP in the DOS-prompt, every node in a network can be clearly identified via its MAC-ID.

- Write a ping command for the respective station/ IP address: (example: "x:\ping 192.168.1.100").
- Via the command "x:\arp -a", the MAC-ID (00-07-46-ff-60-13) for this IP address is determined. This MAC-ID clearly identifies the network node.

Figure 3-3:
Determination
of the MAC-ID of
a BL20 module
via ARP

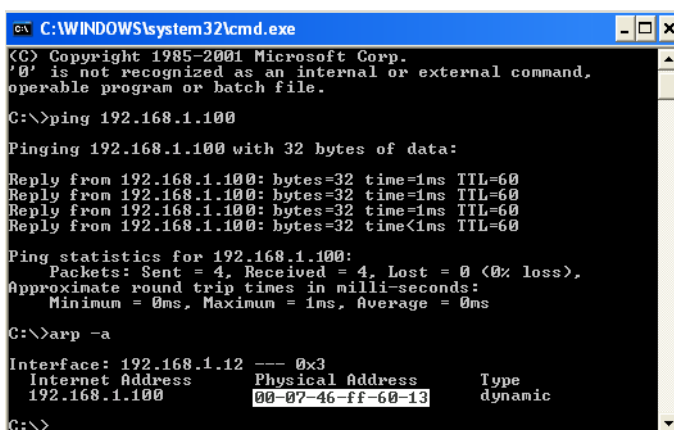

```

C:\WINDOWS\system32\cmd.exe
(C) Copyright 1985-2001 Microsoft Corp.
'0' is not recognized as an internal or external command,
operable program or batch file.

C:\>ping 192.168.1.100

Pinging 192.168.1.100 with 32 bytes of data:

Reply from 192.168.1.100: bytes=32 time=1ms TTL=60
Reply from 192.168.1.100: bytes=32 time=1ms TTL=60
Reply from 192.168.1.100: bytes=32 time=1ms TTL=60
Reply from 192.168.1.100: bytes=32 time<1ms TTL=60

Ping statistics for 192.168.1.100:
    Packets: Sent = 4, Received = 4, Lost = 0 (0% loss),
    Approximate round trip times in milli-seconds:
        Minimum = 0ms, Maximum = 1ms, Average = 0ms

C:\>arp -a

Interface: 192.168.1.12 --- 0x3
Internet Address      Physical Address      Type
192.168.1.100         00-07-46-ff-60-13    dynamic

C:\>

```



4 Technical features

4.1	General	2
4.2	Function	3
4.3	Technical data	4
4.3.1	Gateway structure.....	4
4.4	Connection possibilities	6
4.4.1	Field bus connection.....	6
	– Ethernet-connection.....	6
4.4.2	Power Supply via terminal block with screw connection.....	6
4.4.3	Service interface connection (female PS/2 connector)	6
	– Connection with I/O-ASSISTANT-connection cable.....	7
4.5	Address setting	8
4.5.1	LED-behavior	8
4.5.2	Default setting of the gateway.....	9
4.5.3	Address setting via the rotary-mode	9
4.5.4	Address setting via BootP-mode	10
4.5.5	Address setting via DHCP-mode	11
4.5.6	Address setting via PGM-mode.....	12
4.5.7	Address setting via PGM-DHCP.....	13
4.5.8	Address-setting via I/O-ASSISTANT 3 (FDT/DTM).....	14
4.6	SET button	17
4.7	Status indicators/diagnostic messages gateway	18
4.7.1	Diagnostic messages via LEDs.....	18
4.7.2	Diagnostic messages via the process data	21
	– Summarized diagnostics	21
	– Scheduled diagnostics	22
4.8	Status and Control word of the gateway	23
4.8.1	Status word.....	23
4.8.2	Control word.....	23
4.9	Module specific diagnostic messages	24

Technical features

4.1 General

This chapter contains the general technical description of the BL20 gateway for Ethernet. The following technical features are independent of the implemented protocol.

The chapter describes: the technical data, the connection possibilities, the addressing of the gateway etc.

4.2 Function

The gateway is the connection between the BL20 I/O-modules and the Ethernet-network.

It handles the entire process data traffic between the I/O-level and the fieldbus and generates diagnostic information for higher-level nodes and the software tool I/O-ASSISTANT.

4.3 Technical data

Figure 4-1:
BL20-GW-EN-IP

- A** service-interface
- B** module bus LEDs
- C** SET-button
- D** Rotary coding switches
- E** Ethernet
- F** Ethernet LEDs
- G** power supply

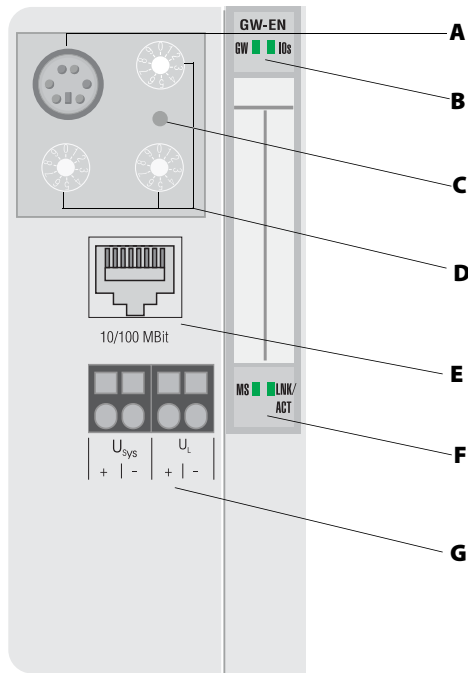

4.3.1 Gateway structure

The BL20 gateway has the following structure:

Figure 4-2:
Gateway structure

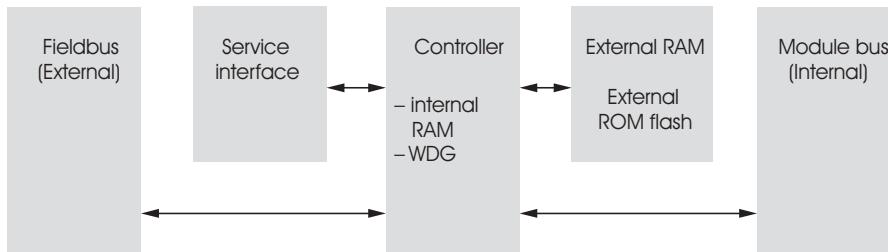

Table 4-1:
Technical data
Ethernet gateway

Supply voltage	
field supply	
U_L nominal value (permissible range)	24 VDC (18 to 30 VDC)
I_L max. field current	10 A
System	24 VDC
U_{sys} nominal value (permissible range)	24 VDC (18 to 30 VDC)
I_{sys}	max. 500 mA
I_{MB} (Supply of the module bus nodes)	max. 1,5 A
Physical interfaces	
field bus	
transmission rate	10/100 MBit/s
passive LWL can be connected	current consumption max. 100 mA
field bus connection technology	RJ45 female connector
field bus shielding connection	via Ethernet cable
Isolation voltages	
U_{RS} (Ethernet/ service interface)	500 V AC
U_{EN} (Ethernet/ module bus)	500 V DC
U_{sys} (U_L to U_{sys})	1000 V DC



Danger

This device can cause radio disturbances in residential areas and in small industrial areas (residential, business and trading). In this case, the operator can be required to take appropriate measures to suppress the disturbance at his own cost.

4.4 Connection possibilities

4.4.1 Field bus connection

Ethernet-connection

The connection to Ethernet is realized via female RJ45 connector:

Figure 4-3:
female RJ45
connector

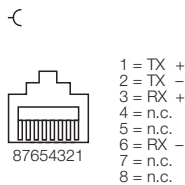

4.4.2 Power Supply via terminal block with screw connection

The power supply is realized via terminal block with screw connection technology.

Table 4-2:
Pin assignment
the terminal
blocks

Signal	Description
U _{sys} +	System supply (Gateway, module bus)
U _{sys} -	
U _L +	Field supply (max. 10 A)
U _L -	

4.4.3 Service interface connection (female PS/2 connector)

The service interface is used to connect the gateway to the project planning and diagnostic software I/O-ASSISTANT.

The service interface is designed as a 6 pole PS/2-connection.

Two types of cables can be used to connect the service interface to a PC.

- special I/O-ASSISTANT-connection cable from TURCK (IOASSISTANT-ADAPTERKABEL-BL20/BL67; Ident-no.: 6827133)
- Commercially available PS/2 cable with adapter cable SUB-D/ PS/2

Connection with I/O-ASSISTANT-connection cable

Figure 4-4:
BL20-gateway
connected to PC
via special cable

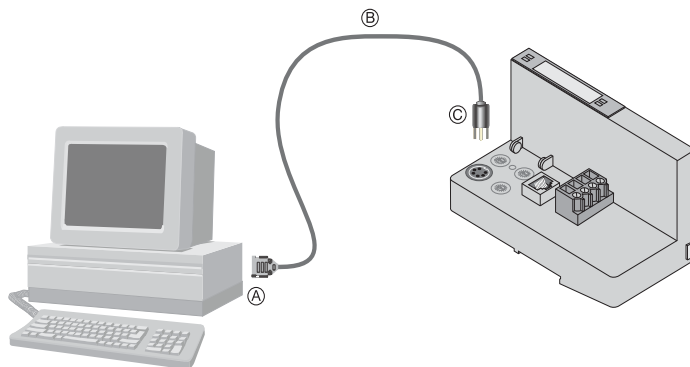

The I/O-ASSISTANT-cables have a PS/2 male connector (connection for female connector on gateway) and a SUB-D female connector (connection for male connector on PC).

Figure 4-5:
PS/2 male con-
nector on the
connection ca-
ble to the gate-
way (top view)



Figure 4-6:
9-pole SUB-D
female connec-
tor on the cable
for connecting
to PC (top view)

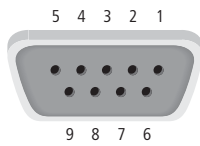

4.5 Address setting

The addressing of the BL20 EtherNet/IP gateway can be realized via different modes:

- rotary mode (manual addressing via rotary coding-switches)
- PGM mode (manual addressing via software)
- BootP mode, DHCP mode (automatic addressing via BootP/DHCP-server at the boot-up of the gateway).

The setting of the address modes is done via the 3 rotary coding-switches at the gateway.



Note

It is not necessary to address the station's internal module bus.



Attention

The cover of the decimal rotary coding-switches must be closed by tightening the screw after use.

The seal in the cover must not be damaged or slipped.

The protection class IP20 can only be guaranteed when the cover is closed correctly.

4.5.1 LED-behavior

During its start-up, the module waits for the address setting via the BootP-server. This is indicated by the red flashing "MS" LED. The LED begins to flash green, as soon as the address setting via the server is completed. The station is ready for communication.

4.5.2 Default setting of the gateway

The gateway's default-settings are the following:

IP address: 192.168.1.254
 subnet mask: 255.255.255.000
 default gateway: 192.168.1.1



Note

The gateway can be reset to these default settings by the user at any time.

To reset the gateway, please set the three coding-switches at the gateway to "000" followed by a power-on reset.

Figure 4-7:
Decimal rotary
coding-switches for the ad-
dress setting

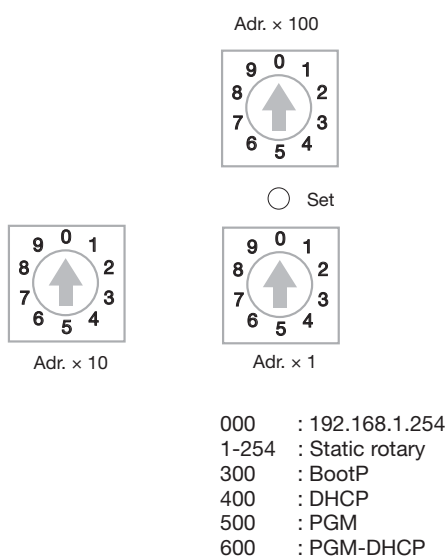

Attention

After every change of the address-mode, a voltage reset must be carried out.

4.5.3 Address setting via the rotary-mode

When using the rotary-mode, the last byte of the gateway's IP address can be set via the rotary coding-switches at the gateway.



Note

All other network settings are stored in the module's non-volatile EEPROM and can not be changed in the rotary-mode.

Addresses in the range from 0 to 254 can be allocated. The addresses 0 and 255 are reserved for broadcast messages in the subnet.

The following example shows the setting of the address **173**.

Figure 4-8:
Address setting

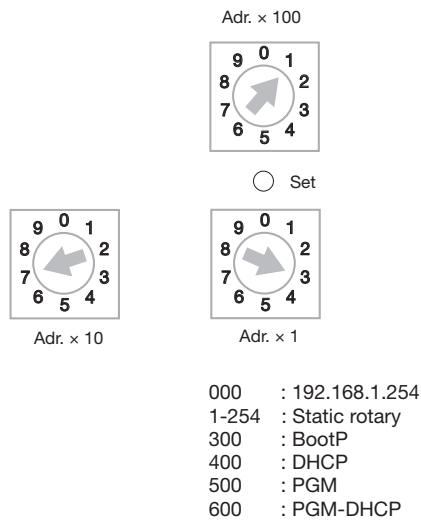

Attention

The settings carried out in the rotary-mode are not stored in the module's EEPROM. Thus, they will get lost in case of a subsequent address-assignment via a BootP/ DHCP or PGM.



Attention

After changing the position of the rotary coding-switches, a voltage reset must be carried out to store the new address.

4.5.4 Address setting via BootP-mode

The address setting is carried out by a BootP-server in the network after the start-up of the gateway. In order to activate the BootP-mode, the rotary coding-switches have to be set to "300".

Figure 4-9:
BootP-mode

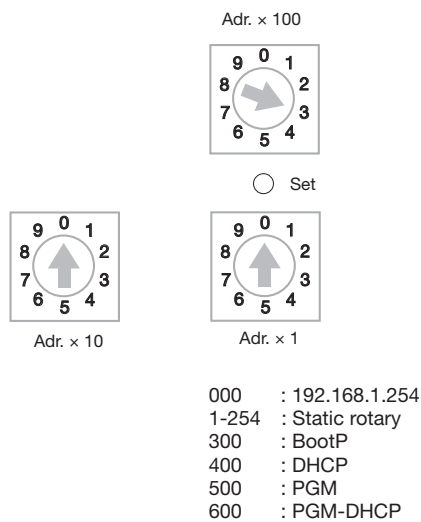

**Note**

The IP address as well as the default subnet mask assigned to the gateway by the BootP-server are stored in the gateway's non-volatile memory.

If the gateway is subsequently switched to rotary- or PGM-mode, the settings carried out via BootP (IP address, subnet mask, etc.) will be taken from the module's EEPROM.

4.5.5 Address setting via DHCP-mode

The address setting is carried out by a DHCP-server in the network after the start-up of the gateway.

In order to activate the DHCP-mode, the rotary coding-switches have to be set to "400".

Figure 4-10:
DHCP-Modus

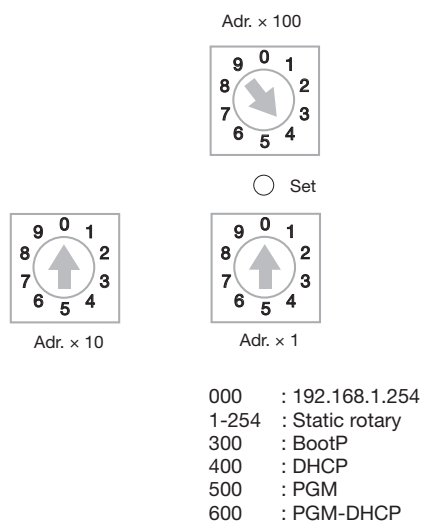
**Note**

The IP address as well as the default subnet mask assigned to the gateway by the DHCP-server are stored in the gateway's non-volatile memory.

If the gateway is subsequently switched to rotary- or PGM-mode, the settings carried out via DHCP (IP address, subnet mask, etc.) will be taken from the module's EEPROM.

DHCP supports three mechanisms for IP address allocation:

- In "automatic allocation", the DHCP-server assigns a permanent IP address to a client.
- In "dynamic allocation", DHCP assigns an IP address to a client for a limited period of time. After this time or until the client explicitly relinquishes the address, the address can be re-assigned.
- In "manual allocation", a client's IP address is assigned by the network administrator, and DHCP is used simply to convey the assigned address to the client.

4.5.6 Address setting via PGM-mode

The PGM-mode enables the access of I/O-ASSISTANTS to the module's network settings.
In order to activate the PGM-mode, the rotary coding-switches have to be set to "500".

Figure 4-11:
PGM-mode

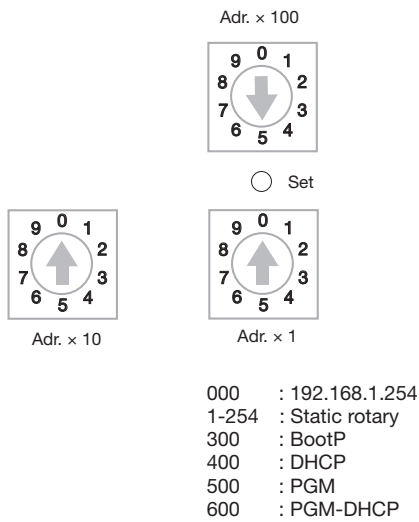

Note

In the PGM-mode, all network settings (IP address, subnet mask, etc.) are read from the module's internal EEPROM.

The settings carried out in the rotary-mode are stored in the module's non-volatile EEPROM.

4.5.7 Address setting via PGM-DHCP

This mode operates exactly like the PGM-mode except that when the gateway is initially powered in this mode it will broadcast its MAC ID (similar to DHCP mode).

But, in contrast to the regular DHCP mode, the DHCP transmission on startup can be enabled/disabled via TCP Object attributes in EtherNet/IP.

In order to activate the PGM-DHCP-mode, the rotary coding-switches must be set to "600".

Figure 4-12:
PGM-DHCPmode

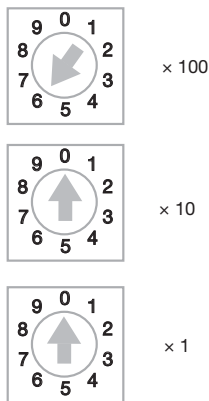

The I/O-ASSISTANT can also be used to set the IP Address in this mode.

This mode is the Out-of-the-Box mode for the gateway and provides powerful and convenient Start-up features.

- 1 DHCP start up –if network contains DHCP server and/or automated configuration setup
- 2 Easy Rockwell BOOTP/DHCP-Server manipulation allowing TCP object access.

4.5.8 Address-setting via I/O-ASSISTANT 3 (FDT/DTM)

The software I/O-ASSISTANT enables direct access to the Ethernet-network via an Ethernet-cable.

Naturally, the access to the single station via the service interface at the gateway is possible as well.

The IP address, as well as the subnet mask of the TURCK Ethernet modules, can be changed according to the application by using the Busaddress Management function of the BL Service Ethernet interface in the I/O-ASSISTANT.



Note

Please observe, the changing the IP-Address is only possible by using the gateway's Ethernet interface. Select the interface "BL Service Ethernet" in the DTM and connect the gateway to the PC using the Ethernet port ([page 4-6](#)).

Changing the address using the service-interface is not possible.

Figure 4-13:
BL Service
Ethernet

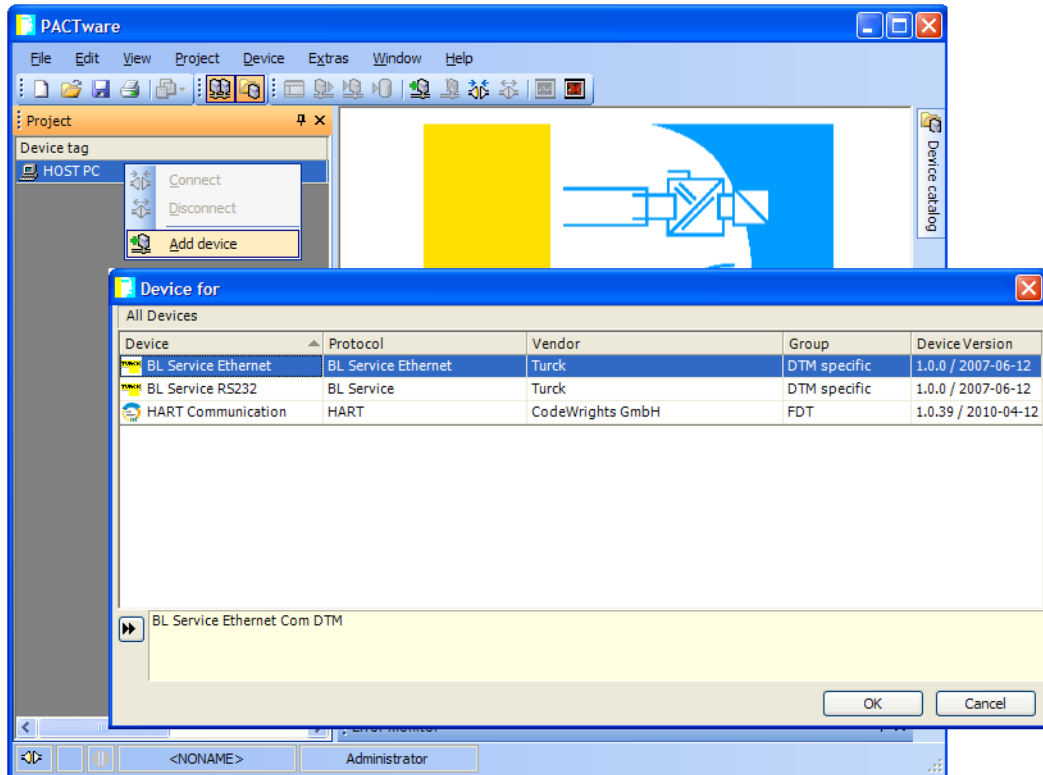

Figure 4-14:
Busaddress management

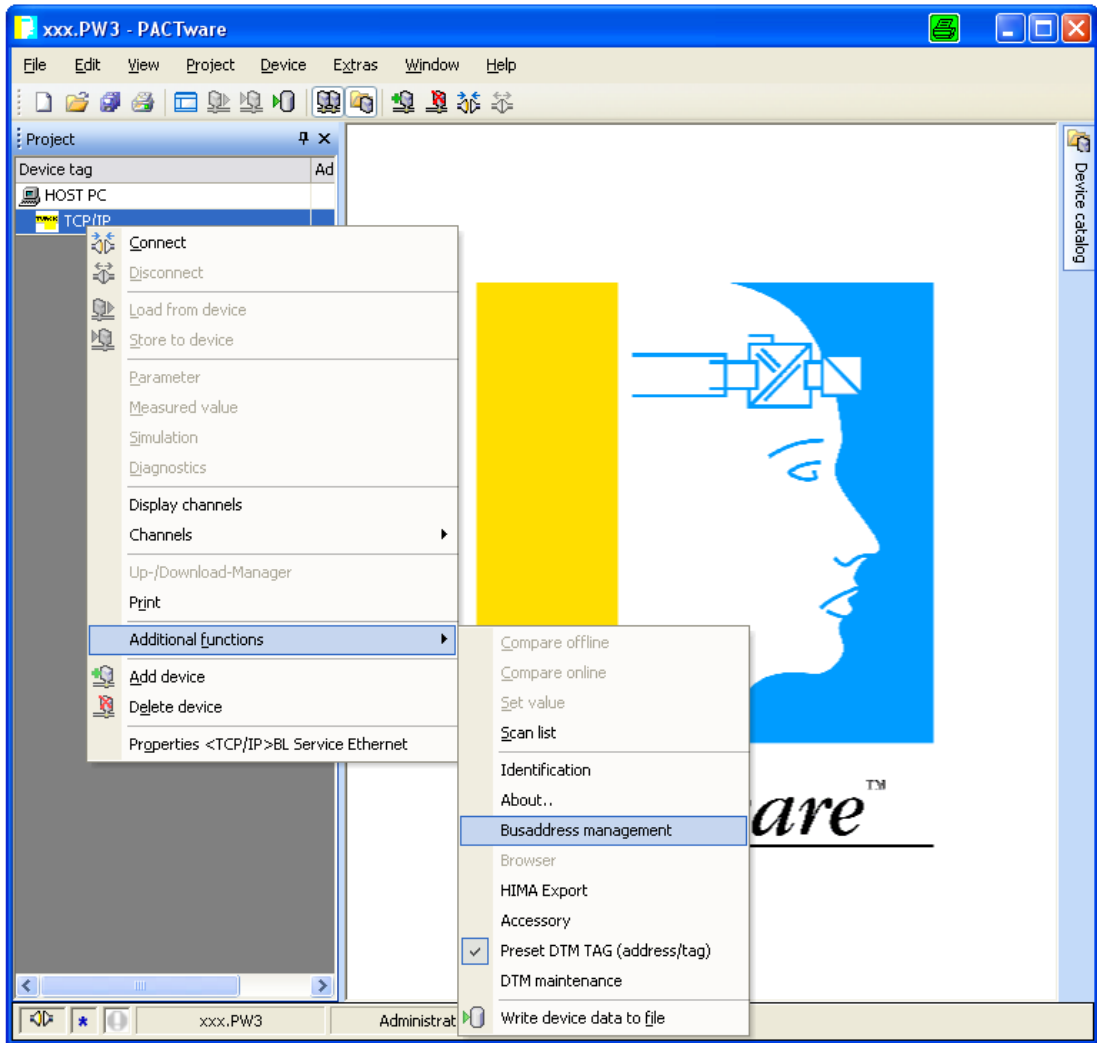
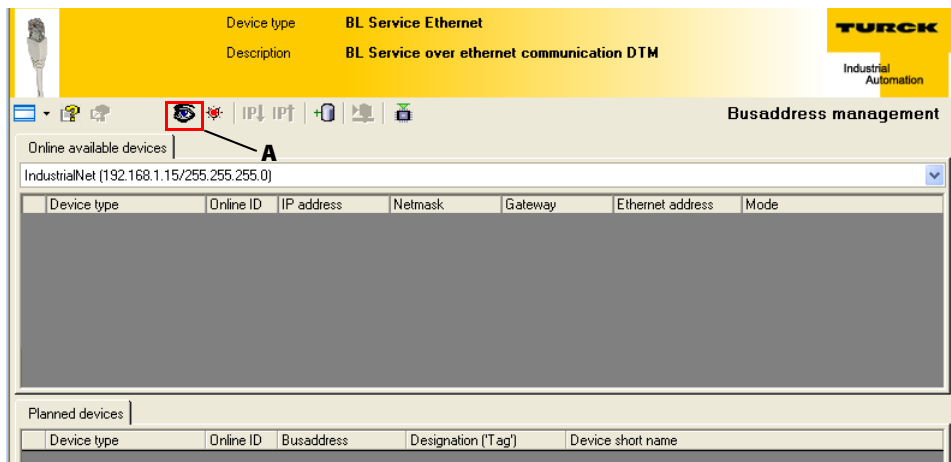

Figure 4-15:
Search for Network-nodes

A Search function in the busaddress management



The IP address as well as the subnet mask of the TURCK Ethernet gateways can be changed according to the application by using the integrated Busaddress Management function in the IO-ASSISTANT 3 (FDT/DTM).



Note

The access of the IO-ASSISTANT to the gateway is only possible if the gateway is operated in PGM-mode (see also [Address setting via PGM-mode \(page 4-12\)](#)).



Attention

When using Windows XP as operating system, difficulties may occur with system-integrated firewall.

It may inhibit the access of PACTware (I/O-ASSISTANT V3) to the Ethernet-network. In this case, please adapt your firewall respectively or deactivate it (see also [Deactivating/ adapting the firewall in Windows XP \(page 6-6\)](#)).

Figure 4-16:
Changing the IP-
address

The screenshot shows the 'Busaddress management' window. At the top, it displays 'Device type: BL Service Ethernet' and 'Description: BL Service over ethernet communication DTM'. The 'Online available devices' section contains a table with the following data:

Device type	Online ID	IP address	Netmask	Gateway	Ethernet address	Mode
Unknown	0	192.168.119.169	255.255.0.0	192.168.1.252	00:07:46:00:04:4B	DHCP
BL20-GW-EN-IP	1118110	192.168.1.99	255.255.255.0	192.168.1.1	00:07:46:00:0F:CA	ROTARY
Unknown	0	192.168.250.31	255.255.0.0	192.168.1.252	00:07:46:00:0A:04	BOOTP
Unknown	0	136.129.1.254	255.255.255.0	136.129.1.1	00:07:46:FF:0A:FD	ERR
BL20-E-GW-EN	801F	192.168.1.254	255.255.255.0	192.168.1.1	00:BD:33:06:68:22	PGM
Unknown	0	192.168.250.254	255.0.0.0	192.168.119.252	00:07:33:06:61:23	ERR

The 'Planned devices' section is currently empty. At the bottom of the window, there are 'OK', 'Cancel', and 'Apply' buttons, and a status bar showing 'Disconnected' and 'Data set'.



Note

Please observe that changing the IP-address is only possible via the Ethernet interface at the gateway, not via the service-interface.

4.6 SET button

The Current Configuration of the station is saved as the Actual Configuration when the SET button on the gateway is pressed for approximately 10 seconds; it is also saved to the both the Temp-Required Configuration Memory and the Required Configuration Memory. The LED "GW" flashes.

4.7 Status indicators/diagnostic messages gateway

The gateway sends the following diagnostic messages:

- undervoltage monitoring for system- and field supply,
- monitoring of the station status,
- monitoring of the communication via the internal module bus,
- monitoring of the communication to Ethernet
- monitoring of the gateway status

Diagnostic messages are displayed in two different ways:

- via the LEDs
- via the respective configuration software

4.7.1 Diagnostic messages via LEDs

Every BL20 gateway displays the following statuses via LEDs:

- 2 LEDs for module bus communication (module bus LEDs): **GW** and **IO**
- 2 LEDs for the Ethernet communication (fieldbus-LEDs): **LNK/ACT** and **MS**.

Table 4-3:
LED-displays

LED	Status	Meaning	Remedy
GW	Off	CPU not supplied.	– Check the voltage supply at the gateway.
	Green	Firmware active, gateway ready to operate and transmit	–
	Green, flashing, 1 Hz	Firmware not active.	If LED "IO" red → Firmware download necessary
	Green, flashing, 4 Hz	Firmware active, gateway hardware defect.	Replace the gateway.
	Red	Controller is not ready, VCC level is not within the required range → possible reasons: – too many modules connected to the gateway – short circuit in connected module – hardware error in gateway	– Check wiring at the gateway and the voltage supply. – Dismount modules – Replace the gateway.

Table 4-3:
LED-displays

LED	Status	Meaning	Remedy
IO	Off	CPU not supplied.	– Check the voltage supply at the gateway.
	Green	Module bus is running, the configured module bus station corresponds to the physically connected station, communication is active.	–
	Green, flashing 1 Hz	Station is in the I/O-ASSISTANT Force Mode.	– Deactivate the I/O-ASSISTANT Force Mode.
	Green, flashing 4 Hz	Maximum number of modules at the gateway is exceeded.	– Check the number of modules connected to the gateway, dismount modules
	Red	Controller is not ready, V_{CC} level is not within the required range → possible reasons: – too many modules connected to the gateway – short circuit in connected module – hardware error in gateway	– Check wiring at the gateway and the voltage supply. – Dismount modules – Replace the gateway.
	Red flashing, 1 Hz	Non-adaptable modification of the physically connected station.	– Compare the planned BL20 station with the physical station. – Check the physical station for defective or incorrectly fitted electronics modules.
	Red flashing, 4 Hz	no module bus communication	– At least one module has to be plugged and has to be able to communicate with the gateway.
	Red/green flashing, 1 Hz	Adaptable modification of the physically connected station; data transfer possible	– Check the physical station for pulled or new but not planned modules.
LNK/ACT	Off	No Ethernet link	– Check the Ethernet-connection
	Green	Link, 100 Mbit	–
	Green flashing	Ethernet Traffic, 100 Mbit	–
	Yellow	Link, 10 Mbit	–
	Yellow, flashing	Ethernet Traffic, 10 Mbit	–

Technical features

Table 4-3:
LED-displays

LED	Status	Meaning	Remedy
MS	Green	Displays an active CIP Class 1 I/O connection	–
	Green, flashing	Gateway is ready for operation	–
	Red	Gateway indicates error	–
	Red, flashing	DHCP/BootP search of settings	–

4.7.2 Diagnostic messages via the process data

Besides the evaluation of diagnostic data via Explicit Messages, BL20 for EtherNet/IP offers the possibility of mapping diagnostic data into the gateways' process data.

2 different forms of diagnostic data handling are provided:

- Summarized Diagnostics
- Scheduled Diagnostics

Summarized diagnostics



Note

The Summarized Diagnostics possibility is only implemented in gateways with Maj. Rev. \geq 1.6.0.

The summarized diagnostic data mode will send back 1 bit for each slice within the station. This bit will be "0" if there are no diagnostic flags set on the slice. If there are any diagnostic events on the slice the bit will be set to "1".

Values:

0 = ok

1 = module sends diagnostics, wrong module or module pulled (acc. to VSC 100, Gateway Class, Attr. 116, [page 5-27](#)).

The diagnostic bits are placed at the end of the input data. The diagnostic data start WORD aligned (see [Data mapping for gateways with rev. < 1.6.0 \(page 5-15\)](#)).

Scheduled diagnostics



Note

The Scheduled Diagnostics possibility is only implemented in gateways with Maj. Rev. \geq 1.6.0.

The scheduled diagnostic data map is a time sliced module related data block, which holds diagnostic data of all modules with active diagnostics using a round robin mechanism.

This diagnostic "window" visualizes a specific module diagnostic data for approx. 125 ms and changes over to the next active diagnostics afterwards. This is done automatically by the gateway.

The data length for the scheduled diagnostics is set according to properties of the modules attached to the gateway.

Word	Byte	Data
0	0	Slot number of the module which sends the diagnostic data.
	1	State of the diagnostic message: bit 5 = 1: diagnostic active bit 6 = 1: wrong module bit 7 = 1: module pulled (acc. to VSC 100, Gateway Class, Attr. 116, page 5-28)
n		Module diagnostics from the module actually referenced by the round robin mechanism.

The scheduled diagnostic data is placed at the end of the input data and after the summarized diagnostic data (see [page 4-21](#)).

4.8 Status and Control word of the gateway

4.8.1 Status word

The gateways status word is mapped into the process data (see also [Mapping of process data \(page 5-13\)](#)) and contains common diagnostic messages such as:

- gateway errors
- module bus errors
- voltage errors
- configuration/ diagnostic warnings

Table 4-4:
Status Word

Bit-No.	Meaning
15	"I/O Controller Error" The communication controller for the I/O-system is faulty.
14	"Force Mode Active Error" The Force Mode is activated.
13	reserved
12	
11	"I/O CfgModified Error" The I/O-configuration has been changed and is now incompatible.
10	"I/O Communication Lost Error" No communication on the I/O module bus.
9	"Usys too low" System supply voltage too low (< 18 VDC).
8	"Usys too high" System supply voltage too high (> 30 VDC).
7	"UL too low" Load voltage too low (< 18 VDC).
6	"UL too high" Load voltage too high (> 30 VDC)
5	"Isys too high" Overload of the system voltage supply.
4	reserved
3	"I/O CfgModified Warning"
2	reserved
1	
0	"I/O DiagActive Warning" At least one I/O-module sends active diagnostics.

It can also be accessed via the Gateway Class VSC 100, Object Instance 2, Gateway Instance, attribute 109 (0x6D) "STATUS REGISTER 2" (for detailed information, see [STATUS REGISTER 2 \(page 5-26\)](#)).

4.8.2 Control word

The control word is mapped into the station's process data. At present, it is not used but reserved for further use (see also [Mapping of process data \(page 5-13\)](#)).

4.9 Module specific diagnostic messages

Detailed module specific diagnostic messages can be read out from Gateway Class VSC 100, Object Instance 2, Gateway Instance, attribute 116 (0x74) "MODULE DIAG SUMMARY" (for detailed information, see also [page 5-28](#)).

5 Implementation of EtherNet/IP

5.1	The EtherNet/IP Communications Profile	3
5.1.1	I/O Messages.....	3
5.1.2	Explicit Messages.....	3
5.1.3	Communications profile of the BL20 EtherNet/IP gateway.....	3
	– Point to point.....	3
	– Multicast.....	3
	– COS I/O connection.....	3
	– Cyclic I/O connection.....	4
	– UCMM.....	4
	– Connected Explicit messaging.....	4
5.2	Classes and instances of the EtherNet/IP-gateway	5
5.2.1	EtherNet/IP Standard Classes	5
5.2.2	Identity Object (0x01)	6
5.2.3	Message Router Object (0x02).....	8
	– Message Router Request/Response Formats	9
5.2.4	Assembly Object.....	13
	– Instance 101	14
	– Instance 102.....	14
	– Instance 103 + Instance 104.....	14
	– Mapping of Process Data	14
	– Data mapping for gateways with rev. < 1.6.0	15
	– Data mapping for gateways with rev. ≥ 1.6.0	16
5.2.5	Connection Manager Object (0x06).....	17
5.2.6	Port Object (0xF4).....	17
5.2.7	TCP/IP Interface Object (0xF5)	18
5.2.8	Ethernet Link Object (0xF6)	23
5.3	VSC-Vendor Specific Classes	25
5.3.1	Class Instance of the VSC.....	26
5.3.2	Gateway Class (VSC 100).....	27
	– Object Instance 1.....	27
	– Object Instance 2.....	28
5.3.3	Terminal Slot Class (VSC 101).....	30
	– Object Instance	30
5.3.4	Process Data Class (VSC102).....	32
	– Object Instance 1, standard input process data (compressed)	32
	– Object Instance 2, standard output process data (compressed)	32
	– Object Instance 3, diagnostic instance	33
	– Object Instance 4, COS/CYCLIC instance.....	33
5.3.5	Power Supply Module Class (VSC103)	34
	– Object Instance	34
5.3.6	Digital Input Module Class (VSC104).....	36
	– Object Instance	36
5.3.7	Digital Output Module Class (VSC105)	38
	– Object Instance	38
5.3.8	Analog Input Voltage Module Class (VSC106)	40
	– Object Instance	40
5.3.9	Analog Output Voltage Module Class (VSC107)	42
	– Object Instance	42
5.3.10	Analog Input Current Module Class (VSC108)	44
	– Object Instance	44

Implementation of EtherNet/IP

5.3.11	Analog Output Current Module Class (VSC109).....	46
	– Object Instance.....	46
5.3.12	Analog Input PT100/NI Module Class (VSC110).....	48
	– Object Instance.....	48
5.3.13	Analog Input THERMO Module Class (VSC111)	51
	– Object Instance.....	51
5.3.14	Counter Module Class (VSC112).....	54
	– Object Instance.....	54
5.3.15	RS232 Module Class (VSC114).....	60
	– Object Instance.....	60
5.3.16	RS485/422 Module Class (VSC115).....	67
	– Object Instance.....	67
5.3.17	SSI Module Class (VSC116)	74
	– Object Instance.....	74
5.3.18	Digital Versatile Module Class (VSC117).....	82
	– Object Instance.....	82
5.3.19	Analog Versatile Module Class (VSC118).....	86
	– Object Instance.....	86
5.3.20	SWIRE module class (VSC121)	89
	– Object Instance.....	89
5.3.21	RFID-S module class (VSC124).....	94
	– Object Instance	94

5.1 The EtherNet/IP Communications Profile

EtherNet/IP is based on a connection-oriented communication model. This means that it is only possible to exchange data via specified connections assigned to the devices.

Communication between the nodes in the EtherNet/IP network can be carried out either via I/O Messages or Explicit Messages.

5.1.1 I/O Messages

I/O Messages serve to exchange high priority process and application data over the network. Communication between the slaves in the EtherNet/IP network is carried out according to the Server/Client Model, which means a producing application transmits data to another or a number of consuming applications. It is quite possible that information is passed to a number of Application Objects in a single device.

5.1.2 Explicit Messages

Explicit Messages are used to transmit low-priority configuration data, general management data or diagnostic data between two specific devices. This is a point-to-point connection in a Server/Client System that requires a request from a client always to be confirmed by a response from the server.

Explicit messages, whether connected or unconnected, use the Message Router (for detailed information, read [section "Message Router Request/Response Formats"](#), page 5-9).

- Message Router Request
Consists of a service code, path size value, a message router path and service data. An EPATH is used in the message router path to indicate the target object.
- Message Router Response
Consists of a service field with the most significant bit set. This is an echo of the service code in the request message with the most significant bit set. A reserved byte follows the service code, which is followed by the General Status code.

5.1.3 Communications profile of the BL20 EtherNet/IP gateway

The EtherNet/IP gateway behaves as an EtherNet/IP Server in the network; the scanner of the higher-level controller operates as a EtherNet/IP Client.

The following EtherNet/IP communications types are supported:

- Point to Point or Multicast
- Cyclic Connection
- Unconnected (UCMM) Explicit Messaging
- Connected Explicit Messaging

Point to point

A connection that exists between two nodes only.

Multicast

A packet with a special destination address, which multiple nodes on the network may be willing to receive.

COS I/O connection

COS (Change Of State) I/O Connections establish event-controlled connections. This means that the EtherNet/IP devices generate messages as soon as a change of status occurs.

Cyclic I/O connection

Messages are triggered time-controlled in Cyclic I/O connections by means of a time generator.

UCMM

The EtherNet/IP gateway offers the option of establishing explicit messaging via the UCMM port (Unconnected Message Manager Port).

UCMM-based explicit messaging is normally used for random, non-periodic requests. It is not recommended for frequent messaging because the UCMM input queue in a product is typically limited to just a few messages. Once this limit is reached, subsequent requests are ignored and must be retried.

Connected Explicit messaging

CIP is a connection-based system. For most communications between nodes, a connection is used.

A connection is a path or a virtual circuit between two or more end points in a system. The purpose is to transfer data in the most efficient manner possible.

The Connection ID is a number that is associated with a communication relationship. Receiving nodes decode this key to know whether they must accept the data or not.

5.2 Classes and instances of the EtherNet/IP-gateway

5.2.1 EtherNet/IP Standard Classes

The BL20 gateway supports the following EtherNet/IP Standard Classes in accordance with the CIP specification.

Table 5-1:
EtherNet/IP
Standard
Classes

Class Code	Object-Name	Description
01 (0x01)	„Identity Object (0x01)“	The Identity Object is required on all devices and provides general information about the device. It enables clear and unambiguous identification of modules. Contains information such as manufacturer name, product type, ident number, revision number etc.
02 (0x02)	„Message Router Object (0x02)“	The Message Router Object provides a messaging connection point through which a Client may address a service to any object class or instance residing in the physical device.
04 (0x04)	„Assembly Object“	The Assembly Object binds attributes of multiple objects, which allows data to or from each object to be sent or received over a single connection. Assembly objects can be used to bind input data or output data. The terms "input" and "output" are defined from the network's point of view. An input will produce data on the network and an output will consume data from the network.
06 (0x06)	„Connection Manager Object (0x06)“	The Connection Manager Class allocates and manages the internal resources associated with both I/O and Explicit Messaging Connections. The specific instance generated by the Connection Manager Class is referred to as a Connection Instance or a Connection Object.
15 (0x0F)	Parameter Object	currently not supported
244 (0xF4)	„Port Object (0xF4)“	Provides a standard way of describing a device's ports.
245 (0xF5)	„TCP/IP Interface Object (0xF5)“	Contains the device TCP/IP-related configuration information.
246 (0xF6)	„Ethernet Link Object (0xF6)“	Contains link-specific counters and status information for an Ethernet 802.3 communications interface.

5.2.2 Identity Object (0x01)

The following description of the Identity Object is taken from the CIP specification, Vol. 1, Rev. 2.1, by ODVA & ControlNet International Ltd. and adapted to BL20.

Class Attributes

Table 5-2:
Class attributes

Attr. No.	Attribute Name	Get/Set	Type	Value
1 (0x01)	REVISION	G	UINT	1
2 (0x02)	MAX OBJECT INSTANCE	G	UINT	1
6 (0x06)	MAX CLASS ATTRIBUTE	G	UINT	7
7 (0x07)	MAX INSTANCE ATTRIBUTE	G	UINT	7

Instance Attributes

Table 5-3:
Instance attributes

Attr. No.	Attribute Name	Get/Set	Type	Description
1 (0x01)	VENDOR	G	UINT	Contains the vendor ID, managed by the Open DeviceNet Vendor Association, Inc. (ODVA) and ControlNet International (CI): TURCK = 48
2 (0x02)	PRODUCT TYPE	G	UINT	Indicates the general type of product. Communications Adapter 12 _{dez} = 0x0C
3 (0x03)	PRODUCT CODE	G	UINT	Identifies a particular product within a device type. Default: 27247
4 (0x04)	REVISION Major Minor	G	STRUCT OF: USINT USINT	Revision of the item the Identity Object is representing. 0x01 0x06
5 (0x05)	DEVICE STATUS	G	WORD	See Table 5-4: Device Status
6 (0x06)	SERIAL NUMBER	G	UDINT	Contains the ident-no. of the product (3 last bytes of the MAC-ID).
7 (0x07)	PRODUCT NAME LENGTH NAME	G	STRUCT OF: USINT STRING [13]	BL20-GW-EN-IP

Device Status

Table 5-4:
Device Status

Bit	Name	Definition
0 to 1	reserved	Default = 0
2	Configured	TRUE → The application of the device has been configured (≠ default-settings).
3	reserved	Default = 0
4 to 7	Extended Device Status	0011 = No I/O connections established 0110 = At least one I/O connection in run mode 0111 = At least one I/O connection established, all in idle mode All other settings = reserved
8 to 15	reserved	Default = 0

Common Services

Table 5-5:
Common services

Service Code	Class	Instance	Service Name
01 (0x01)	yes	yes	Get_Attribute_All Returns a predefined listing of this objects attributes.
05 (0x05)	no	yes	Reset Starts the Reset service for the device.
14 (0x0E)	yes	yes	Get_Attribute_Single Returns the contents of a specified attribute.
16 (0x10)	no	no	Set_Attribute_Single Modifies a single attribute.

5.2.3 Message Router Object (0x02)

This object provides a messaging connection point through which a Client may address a service to any object class or instance residing in the physical device.

The following description of the Message Router Object is taken from the CIP specification, Vol. 1, Rev. 2.1 by ODVA & ControlNet International Ltd. and adapted to BL20.

Class Attributes

Table 5-6: Class attributes

Attr. No.	Attribute Name	Get/Set	Type	Value
1 (0x01)	REVISION	G	UINT	1
4 (0x04)	OPTIONAL ATTRIBUTE NUMBER	G	UINT	0
5 (0x05)	OPTIONAL SERVICE NUMBER	G	UINT	0
6 (0x06)	MAX CLASS IDENTIFIER	G	UINT	7
7 (0x07)	MAX INSTANCE ATTRIBUTE	G	UINT	2

Instance Attributes

Table 5-7: Instance attributes

Attr. No.	Attribute Name	Get/Set	Type	Description
1 (0x01)	OBJECT LIST	G	STRUCT OF	Structure with an array of object class-codes supported by the device.
	NUMBER	G	UINT	Depending
	CLASSES	G	ARRAY of UINT	Number of the classes supported by the gateway.
2 (0x02)	MAX NUMBER OF CONNECTIONS	G	UINT	Count of the maximum number of connections supported.

Common Services

Table 5-8: Common services

Service Code	Class	Instance	Service Name
01 (0x01)	yes	yes	Get_Attribute_All
14 (0x0E)	yes	yes	Get_Attribute_Single

Message Router Request/Response Formats

■ Message Router Request Format:

Table 5-9: Message Router Request

Parameter	Data Type	Description
Service	USINT	Service code of the request.
Request Path Size	USINT	Number of 16 bit words in the "Request Path".
Request Path	Padded EPATH	Array of bytes containing the information for the path of request (class ID, Instance ID, etc.) for this transaction.
Request Data	Array of octed	Additional service specific data to be delivered in the Explicit Messaging Request.

■ Message Router Response Format:

Table 5-10: Message Router Response

Parameter	Data Type	Description
Reply Service	SINT	Reply service code.
General Status	USINT	General Status Code according to CIP specification. See Table 5-11: General Status Codes according to CIP spec.
Size of Additional Status	USINT	Number of 16 bit words in Additional status.
Additional Status	Array of USINT	Additional status.
Response Data	Array of octet	Response data from request or additional error data if an error was indicated in "General Status".

Table 5-11: General Status Codes according to CIP spec.

Status Code (hex)	Status Name	Description
00	Success	Service successfully performed by the object specified.
01	Connection failure	A connection related service failed along the connection path.
02	Resource unavailable	Resources needed for the object to perform the requested service were unavailable.
03	Invalid parameter value	See Status Code 0x20, which is the preferred value to use for this condition.
04	Path segment error	The path segment identifier or the segment syntax was not understood by the processing node. Path processing shall stop when a path segment error is encountered.

Table 5-11:
General Status
Codes
according to CIP
spec.

Status Code (hex)	Status Name	Description
05	Path destination unknown	The path is referencing an object class, instance or structure element that is not known or is not contained in the processing node. Path processing shall stop when a path destination unknown error is encountered.
06	Partial transfer	Only part of the expected data was transferred.
07	Connection lost	The messaging connection was lost.
08	Service not supported	The requested service was not implemented or was not defined for this Object Class/Instance.
09	Invalid attribute value	Invalid attribute data detected.
0A	Attribute list error	An attribute in the Get_Attribute_List or Set_Attribute_List response has a non-zero status.
0B	Already in requested mode/state	The object is already in the mode/state being requested by the service.
0C	Object state conflict	The object cannot perform the requested service in its current mode/state.
0D	Object already exists	The requested instance of object to be created already exists.
0E	Attribute not settable	A request to modify a non-modifiable attribute was received.
0F	Privilege violation	A permission/privilege check failed.
10	Device state conflict	The device's current mode/state prohibits the execution of the requested service.
11	Reply data too large	The data to be transmitted in the response buffer is larger than the allocated response buffer.
12	Fragmentation of a primitive value	The service specified an operation that will fragment a primitive data value, i.e. half a REAL data type.
13	Not enough data	The service did not supply enough data to perform the specified operation.
14	Attribute not supported	The attribute specified in the request is not supported.
15	Too much data	The service supplied more data than expected.
16	Object does not exist	The object specified does not exist in the device.
17	Service fragmentation sequence not in progress	The fragmentation sequence for this service is not currently active for this data.

Table 5-11:
General Status
Codes
according to CIP
spec.

Status Code (hex)	Status Name	Description
18	No stored attribute data	The attribute data of this object was not saved prior to the requested service.
19	Store operation failure	The attribute data of this object was not saved due to a failure during the attempt.
1A	Routing failure, request packet too large	The service request packet was too large for transmission on a network in the path to the destination. The routing device was forced to abort the service.
1B	Routing failure, response packet too large	The service response packet was too large for transmission on a network in the path from the destination. The routing device was forced to abort the service.
1C	Missing attribute list entry data	The service did not supply an attribute in a list of attributes that was needed by the service to perform the requested behavior.
1D	Invalid attribute value list	The service is returning the list of attributes supplied with status information for those attributes that were invalid.
1E	Embedded service error	An embedded service resulted in an error.
1F	Vendor specific error	A vendor specific error has been encountered. The Additional Code Field of the Error Response defines the particular error encountered. Use of this General Error Code should only be performed when none of the Error Codes presented in this table or within an Object Class definition accurately reflect the error.
20	Invalid parameter	A parameter associated with the request was invalid. This code is used when a parameter does not meet the requirements of this specification and/or the requirements defined in an Application Object Specification.
21	Write-once value or medium already written	An attempt was made to write to a write-once medium (e.g. WORM drive, PROM) that, has already been written, or to modify a value that cannot be changed once established.
22	Invalid Reply Received	An invalid reply is received (e.g. reply service code does not match the request service code, or reply message is shorter than the minimum expected reply size). This status code can serve for other causes of invalid replies.
23 to 24	Reserved by CIP for future extensions	
25	Key Failure in path	The Key Segment that was included as the first segment in the path does not match the destination module. The object specific status shall indicate which part of the key check failed.
26	Path Size Invalid	The size of the path which was sent with the Service Request is either not large enough to allow the Request to be routed to an object or too much routing data was included.

Table 5-11:
General Status
Codes
according to CIP
spec.

Status Code (hex)	Status Name	Description
27	Unexpected attribute in list	An attempt was made to set an attribute that is not able to be set at this time.
28	Invalid Member ID	The Member ID specified in the request does not exist in the specified Class/Instance/Attribute
29	Member not settable	A request to modify a non-modifiable member was received
2A	Group 2 only server general failure	This error code may only be reported by Group 2 Only servers with 4K or less code space and only in place of Service not supported, Attribute not supported and Attribute not settable.
2B to CF	Reserved by CIP for future extensions	
D0 to FF	Reserved for Object Class and service errors	This range of error codes is to be used to indicate Object Class specific errors. Use of this range should only be performed when none of the Error Codes presented in this table accurately reflect the error that was encountered.

5.2.4 Assembly Object

Assembly Objects bind attributes of multiple objects to allow data to or from each object to be sent or received over a single connection.

The following description of the Assembly Object is taken from the CIP specification, Vol. 1, Rev. 2.1 by ODVA & ControlNet International Ltd. and adapted to BL20.

Class attributes

Table 5-12: Class attributes

Attr. No.	Attribute Name	Get/ Set	Type	Value
1 (0x01)	REVISION	G	UINT	2
2 (0x02)	MAX OBJECT INSTANCE	G	UINT	2

Instance attributes

Table 5-13: Instance attributes

Attr. No.	Attribute Name	Get/ Set	Type	Description
1 (0x01)	NUMBER OF MEMBERS IN LIST	G	UINT	0 (no dynamic)
2 (0x02)	MEMBER LIST	G	ARRAY of STRUCT UINT UINT Packed EPATH	Depends on Instance.
3 (0x03)	DATA	S	ARRAY OF BYTE	
4 (0x04)	SIZE	G	UINT Number of bytes in Attr. 3	256

Common Services

Table 5-14: Common services

Service Code	Class	Instance	Service Name
01 (0x01)	yes	yes	Get_Attribute_All
14 (0x0E)	no	yes	Get_Attribute_Single

Instance 101

Contains the station's input data (static length 256 bytes).

- 2 Bytes status information (see [page 5-28](#))
- + process data

Instance 102

Contains the station's output data (static length 256 bytes).

- 2 Bytes Control data (mapped, but not defined)
- + process data

Instance 103 + Instance 104

In- and output assembly instances with variable assembly sizes. The assembly size is precalculated to support the stations I/O-configuration, RFID Command interface configuration, enabled diagnostics, etc.

- input assembly instance: 103
- output assembly instance: 104

The size of each assembly instance can be retrieved through the assembly object, instance 0x67, attribute: 0x04 and can vary between 2 and 496 bytes.

Mapping of Process Data

The process image of the BL20 gateway is depicted in WORD format (16 bit). The process data of successive modules of the same type, with process data of less than 1 word, are grouped together until 16 bits of process data is reached. The process data is written in a new word when:

- 16-bit input data is reached and further input modules follow
- 16-bit output data is reached and further output modules follow
- An input module, whose process data length cannot be completely incorporated in the preceding word, follows on from another input module
- An output module, whose process data length cannot be completely incorporated in the preceding word, follows on from another output module

Example station (I/O-modules)

- Module A: Gateway
- Module B: BL20-4DI-24VDC-P
- Module C: BL20-2AI(-10/0...+10V)
- Module D: BL20-E-8DI-24VDC-P
- Module E: BL20-4DI-24VDC-P
- Module F: BL20-E-8DI-24VDC-P
- Module G: BL20-E-8DO-24VDC-0.5A-P
- Module H: BL20-2AO-I(4...20MA)
- Module I: BL20-4DO-24VDC-0.5A-P
- Module J: BL20-E-8DI-24VDC-P
- Module K: BL20-E-8DO-24VDC-0.5A-P

Data mapping for gateways with rev. < 1.6.0

Table 5-15:
Process image
of example
station

Produced data (word no.)	Input data (WORD format) (Bit 15...→ ...0)
0	Status word (A15 ... A0) of the gateway (see also Status register 2 (page 5-28))
1	B3 ... B0
2	C15 ... C0
3	C31 ... C16
4	E3 ... E0; D7 ... D0
5	J7 ... J0; F7 ... F0
Consumed data (word no.)	Output data (WORD format) (Bit 15...→ ... 0)
0	Control word of the gateway (mapped, but not defined)
1	G7 ... G0
2	H15 ... H0
3	H31 ... H16
4	K7 ... K0; I3 ... I0

The example station transmits **6 word** input data and **5 word** output data accordingly.

**Note**

For more information about data mapping, please read also [chapter 6, Examples for I/O data mapping \(page 6-20\)](#) and [Mapping report via I/O-ASSISTANT \(page 6-22\)](#).

Data mapping for gateways with rev. ≥ 1.6.0

Table 5-16:
Data mapping
for gateways
with rev. ≥
1.3.0.16

Produced Data (word no.)	Input data
0	Status word of the gateway (bit assignment, see Status register 2 (page 5-28) . (Mapping can be disabled using attribute 139 "GW Status Register" in "Gateway Class (VSC 100)", Object Instance 2, page 5-29)
1 to n	Input data of modules Mapping similar to mapping of gateways with older firmware (see above Data mapping for gateways with rev. < 1.6.0 (page 5-15)).
n + y	Summarized diagnostic data (page 4-21) of individual length. Can be enabled/disabled using VSC102, Object instance 3, attr. 104, page 5-33 ff. (y= the no. of following bytes depending on the no. of slices within the station)
n + z	Scheduled diagnostic data (page 4-22). Can be enabled/disabled using VSC102, Object instance 3, attr. 105, page 5-33 ff. (z = data length for the scheduled diagnostics set according to the properties of the modules attached to the gateway)
Consumed Data (word no.)	Output data
0	Control word of the gateway (mapped, but not defined) (Mapping can be disabled using attribute 139 "GW Control Register" in "Gateway Class (VSC 100)", Object Instance 2, page 5-29)
1- n	Output data of the modules Mapping similar to mapping of gateways with older firmware (see above Data mapping for gateways with rev. < 1.6.0 (page 5-15)).



Note

The data mapping can be structured individually. All parts except for the in- and output data of the station can be enabled/ disabled independently from each other.

5.2.5 Connection Manager Object (0x06)

This object is used for connection and connectionless communications, including establishing connections across multiple subnets.

The following description of the Connection Manager Object is taken from the CIP specification, Vol. 1, Rev. 2.1 by ODVA & ControlNet International Ltd. and adapted to BL20.

Common Services

Table 5-17: Common services

Service Code	Class	Instance	Service Name
84 (0x54)	no	yes	FWD_OPEN_CMD (Opens a connection)
78 (0x4E)	no	yes	FWD_CLOSE_CMD (Closes a connection)
82 (0x52)	no	yes	UNCONNECTED_SEND_CMD (Unconnected Send Service. Only originating devices and devices that route between links need to implement).

5.2.6 Port Object (0xF4)

The following description of the Port Object is taken from the CIP specification, Vol. 1, Rev. 2.1 by ODVA & ControlNet International Ltd. and adapted to BL20.

Class Attributes

Table 5-18: Class attributes

Attr. No.	Attribute Name	Get/Set	Type	Value
1 (0x01)	REVISION	G	UINT	1
2 (0x02)	MAX OBJECT INSTANCE	G	UINT	1
3 (0x03)	NUMBER OF INSTANCES	G	UINT	1
8 (0x08)	ENTRY PORT	G	UINT	1
9 (0x09)	ALL PORTS	G	ARRAY of STRUCT UINT UINT	0,0 for class 4,2 for TCP_IP_PORT

Instance Attributes

Table 5-19: Instance attributes

Attr. No.	Attribute Name	Get/Set	Type	Description
1 (0x01)	ATTRIBUTE PORT TYPE	G	UINT	4 for TCP_IP_PORT
2 (0x02)	ATTRIBUTE PORT NUMBER	G	UINT	2
3 (0x03)	ATTRIBUTE PORT OBJECT	G	UINT EPATH Logical path	2 0x12, 0x02 0x00, 0x00

Common Services

Table 5-20: Common services

Service Code	Class	Instance	Service Name
01 (0x01)	yes	yes	Get_Attribute_All
14 (0x0E)	yes	yes	Get_Attribute_Single

5.2.7 TCP/IP Interface Object (0xF5)

The following description of the TCP/IP Interface Object is taken from the CIP specification, Vol. 2, Rev. 1.1 and adapted to BL20.

Class Attributes

Table 5-21: Class attributes

Attr. No.	Attribute Name	Get/Set	Type	Value
1 (0x01)	REVISION	G	UINT	1
2 (0x02)	MAX OBJECT INSTANCE	G	UINT	1
3 (0x03)	NUMBER OF INSTANCES	G	UINT	1
6 (0x06)	MAX CLASS IDENTIFIER	G	UINT	7
7 (0x07)	MAX INSTANCE ATTRIBUTE	G	UINT	6

Instance AttributesTable 5-22:
Instance
attributes

Attr. No.	Attribute Name	Get/ Set	Type	Description
1 (0x01)	STATUS	G	DWORD	Interface status (see page 5-20)
2 (0x02)	CONFIGURATION CAPABILITY	G	DWORD	Interface Capability Flag (see page 5-20)
3 (0x03)	CONFIGURATION CONTROL	G/S	DWORD	Interface Control Flag (see page 5-20)
4 (0x04)	PHYSICAL LINK OBJECT	G	STRUCT	
	Path size		UINT	Number of 16bit words: 0x02
	Path		Padded EPATH	0x20, 0xF6, 0x24, 0x01
5 (0x05)	INTERFACE CONFIGURATION	G	Structure of:	TCP/IP Network Interface Configuration (see page 5-20)
	IP ADDRESS	G	UDINT	Current IP address
	NETWORK MASK	G	UDINT	Current network mask
	GATEWAY ADDRESS	G	UDINT	Current default gateway
	NAME SERVER	G	UDINT	0 = no name server address configured
	NAME SERVER 2		UDINT	0 = no secondary name server address configured
5 (0x05)	DOMAIN NAME	G	UDINT	0 = no Domain Name configured
6 (0x06)	HOST NAME	G	STRING	0 = no Host Name configured (see page 5-21)

Common ServicesTable 5-23:
Common
services

Service Code	Class	Instance	Service Name
01 (0x01)	yes	yes	Get_Attribute_All
02 (0x02)	no	no	Set_Attribute_All
14 (0x0E)	yes	yes	Get_Attribute_Single
16 (0x10)	no	yes	Set_Attribute_Single

■ Interface Status

The Status attribute indicates the status of the TCP/IP network interface.

Refer to the state diagram, [Figure 5-1: TCP/IP object state diagram \(acc. to CIP Spec., Vol.2, Rev. 1.1\)](#) for a description of object states as they relate to the Status attribute.

Table 5-24: Interface Status

Bit(s)	Name	Definition
0-3	Interface Configuration Status	Indicates the status of the Interface Configuration attribute: 0 = The Interface Configuration attribute has not been configured 1 = The Interface Configuration attribute contains valid configuration. 2 to 15 = Reserved
4 to 31	reserved	

■ Configuration Capability

The Configuration Capability indicates the device's support for optional network configuration capability.

Table 5-25: Configuration Capability

Bit(s)	Name	Definition	Value
0	BOOTP Client	The device is capable of obtaining its network configuration via BOOTP.	1
1	DNS Client	The device is capable of resolving host names by querying a DNS server.	0
2	DHCP Client	The device is capable of obtaining its network configuration via DHCP.	1

■ Configuration Control

The Configuration Control attribute is used to control network configuration options.

Table 5-26: Configuration Control

Bit(s)	Name	Definition
0-3	Startup Configuration	Determines how the device shall obtain its initial configuration at start-up. 0 = The device shall use the interface configuration values previously stored (for example, in non-volatile memory or via hardware switches, etc). 1 to 3 = reserved
4	DNS Enable	Always 0.
5-31	Reserved	Set to 0.

■ **Interface Configuration**

This attribute contains the configuration parameters required to operate as a TCP/IP node.

To modify the Interface Configuration attribute, get the Interface Configuration attribute first, change the desired parameters, then set the attribute.

The TCP/IP Interface Object applies the new configuration upon completion of the Set service. If the value of the Startup Configuration bits (Configuration Control attribute) is 0, the new configuration is stored in non-volatile memory.

The device does not reply to the set service until the values are safely stored to non-volatile memory. An attempt to set any of the components of the Interface Configuration attribute to invalid values results in an error (status code 0x09) returned from the Set service.

If initial configuration is obtained via BOOTP or DHCP, the Interface Configuration attribute components are all zeros until the BOOTP or DHCP reply is received.

Upon receipt of the BOOTP or DHCP reply, the Interface Configuration attribute shows the configuration obtained via BOOTP/DHCP.

■ **Host Name**

The Host Name attribute contains the device's host name.

The host name attribute is used when the device supports the DHCP-DNS Update capability and has been configured to use DHCP upon start up.

The mechanism allows the DHCP client to transmit its host name to the DHCP server. The DHCP server then updates the DNS records on behalf of the client. The host name attribute does not need to be set for the device to operate normally. The value of the Host Name attribute, if it is configured, is used for the value of the FQDN option in the DHCP request. If the Host Name attribute has not been configured, then the device shall not include the FQDN option in the DHCP request.

Figure 5-1:
TCP/IP object
state diagram
(acc. to CIP
Spec., Vol.2, Rev.
1.1)

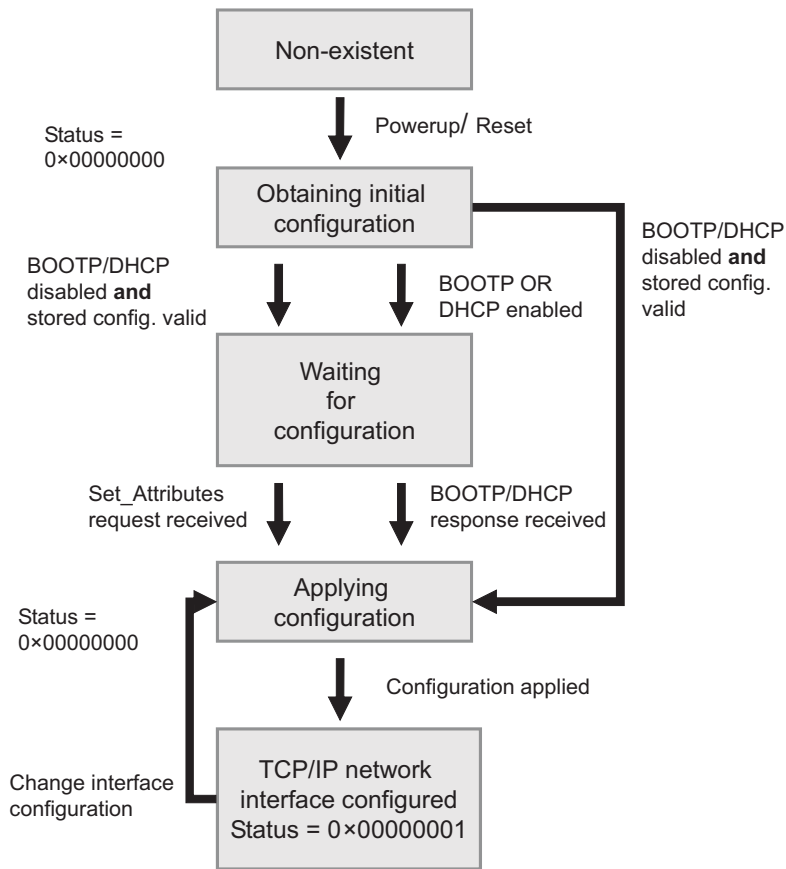

5.2.8 Ethernet Link Object (0xF6)

The following description of the Ethernet Link Object is taken from the CIP specification, Vol. 2, Rev. 1.1 by ODVA & ControlNet International Ltd. and adapted to BL20.

Class Attributes

Attr. No.	Attribute Name	Get/ Set	Type	Value
1 (0x01)	REVISION	G	UINT	1
2 (0x02)	MAX OBJECT INSTANCE	G	UINT	1
3 (0x03)	NUMBER OF INSTANCES	G	UINT	1
6 (0x06)	MAX CLASS IDENTIFIER	G	UINT	7
7 (0x07)	MAX INSTANCE ATTRIBUTE	G	UINT	6

Instance Attributes

Attr. No.	Attribute Name	Get/ Set	Type	Description
1 (0x01)	INTERFACE SPEED	G	UDINT	Speed in megabits per second (e.g., 10, 100, 1000, etc.)
2 (0x02)	INTERFACE FLAGS	G	DWORD	see Table 5-29: Interface flags
3 (0x03)	PHYSICAL ADDRESS	G	ARRAY OF USINT	Contains the interface's MAC address (TURCK: 00:07:46:xx:xx:xx)

Bits	Name	Definition	Default-Value
0	Link Status	Indicates whether or not the Ethernet 802.3 communications interface is connected to an active network. 0 = inactive link 1 = active link.	Depends on application
1	Half / Full Duplex	0 = half duplex; 1 = full duplex If the Link Status flag is 0, the value of the Half/ Full Duplex flag is indeterminate.	Depends on application

Table 5-29: Interface flags

Bits	Name	Definition	Default-Value
2 to 4	Negotiation Status	Indicates the status of link auto-negotiations. 0 = Auto-negotiation in progress 1 = Auto-negotiation and speed detection failed. Using default values for speed and duplex (10Mbps/half duplex). 2 = Auto negotiation failed but detected speed (default: half duplex). 3 = Successfully negotiated speed and duplex. 4 = Auto-negotiation not attempted. Forced speed and duplex.	Depends on application
5	Manual Setting Requires Reset	0 = interface can activate changes to link parameters (auto-negotiate, duplex mode, interface speed) automatically 1 = device requires a Reset service to be issued to its Identity Object in order to adapt the changes	0
6	Local Hardware Fault	0 = interface detects no local hardware fault 1 = a local hardware fault is detected	0

Common Services

Table 5-30: Common services

Service Code	Class	Instance	Service Name
01 (0x01)	yes	yes	Get_Attribute_All
14 (0x0E)	yes	yes	Get_Attribute_Single
76 (0x4C)	no	yes	Enetlink_Get_and_Clear

5.3 VSC-Vendor Specific Classes

In addition to supporting the above named CIP Standard Classes, the BL20 gateway for EtherNet/IP supports the below vendor specific classes.

The VSC describing the possible DeviceNet-master function (VSC 122 and VSC 123) of an EtherNet/IP gateway can be found in a separate manual (D301118).

It is possible to gain read (**G**= Get) and/or write (**S**= Set) access to the attributes of classes described in the following VSC-Vendor Specific Classes

Table 5-31:
VSC-Vendor Specific Classes

Class Code dec. (hex.)	Name	Description
100 (64h)	Gateway Class (VSC 100) (page 5-27)	Contains data and settings concerning the gateway and the BL20 system as a whole.
101 (65h)	Terminal Slot Class (VSC 101) (page 5-30)	Contains data concerning the base modules
102 (66h)	Process Data Class (VSC102) (page 5-32)	Contains process data
103 (67h)	Power Supply Module Class (VSC103) (page 5-34)	Describes the power distribution modules
104 (68h)	Digital Input Module Class (VSC104) (page 5-36)	Describes the modules of the type BL20-*DI-*
105 (69h)	Digital Output Module Class (VSC105) (page 5-38)	Describes the modules of the type BL20-*DO-*
106 (6Ah)	Analog Input Voltage Module Class (VSC106) (page 5-40)	Describes the modules of the type BL20-*AI-U
107 (6Bh)	Analog Output Voltage Module Class (VSC107) (page 5-42)	Describes the modules of the type BL20-*AO-U
108 (6Ch)	Analog Input Current Module Class (VSC108) (page 5-44)	Describes the modules of the type BL20-*AI-I
109 (6Dh)	Analog Output Current Module Class (VSC109) (page 5-46)	Describes the modules of the type BL20-*AO-I
110 (6Eh)	Analog Input PT100/NI Module Class (VSC110) (page 5-48)	Describes the modules of the type BL20-*AI- PT/NI
111 (6Fh)	Analog Input THERMO Module Class (VSC111) (page 5-51)	Describes the modules of the type BL20-*AI-THERMO-PI
112 (70h)	Counter Module Class (VSC112) (page 5-54)	Describes the modules of the type BL20-*CNT-*
114 (72h)	RS485/422 Module Class (VSC115) (page 5-67)	Describes the modules of the type BL20-1RS232
115 (73h)	RS485/422 Module Class (VSC115) (page 5-67)	Describes the modules of the type BL20-1RS485/422
116 (74h)	SSI Module Class (VSC116) (page 5-74)	Describes the modules of the type BL20-1SSI

Table 5-31:
VSC-Vendor
Specific Classes

Class Code dec. (hex.)	Name	Description
117 (75h)	Digital Versatile Module Class (VSC117) (page 5-82)	Describes for example modules of the type BL20-4DI-NAMUR
118 (76h)	Analog Versatile Module Class (VSC118) (page 5-86)	Describes modules of the type BL20-4AI-U/I
121 (79h)	SWIRE module class (VSC121) (page 5-89)	Describes modules of the type BL20-E-SWIRE.
124 (7Ch)	RFID-S module class (VSC124) (page 5-94)	Describes for example modules of the type BL20-2RFID-S

5.3.1 Class Instance of the VSC



Note

The Class Instance attributes are the same for each Vendor Specific Class. The class-specific Object Instances and the corresponding attributes are explained in the paragraphs for the different VSC.

The general VSC - Class Instance attributes are defined as follows:

Table 5-32:
Class instance

Attr. No. dec. (hex.)	Attribute name	Get/ Set	Type	Description
100 (64h)	Class revision	G	UINT	States the revision number of the class (Maj. Rel. *1000 + Min. Rel.).
101 (65h)	Max. instance	G	USINT	Contains the number of the highest instance of an object created on this level in the class hierarchy.
102 (66h)	# of instances	G	USINT	Contains the number of Object Instances created in this class.
103 (67h)	Max. class attribute	G	USINT	Contains the number of the last Class Attribute to be implemented.

5.3.2 Gateway Class (VSC 100)

The Gateway Class contains all the parameters that concern the BL20 system and the gateway.



Note

Please refer to paragraph "Class Instance of the VSC", page 9-6, for the description of the class instance for the VSC.

Object Instance 1

Table 5-33:
Object instance
1, Boot instance

Attr. No. dec. (hex.)	Attribute name	Get/ Set	Type	Description
100 (64h)	Max object attribute	G	USINT	Contains the number of the last object attribute to be implemented
101 (65h)	Hardware revision	G	STRUCT	Contains the hardware revision number of the gateway (USINT Maj./USINT Min.)
102 (66h)	Firmware revision	G	STRUCT	Contains the revision number of the Boot Firmware for DeviceNet (Maj./Min.).
103 (67h)	Service tool ident number	G	UDINT	Contains the BOOT ID number that serves as an identification number for the software I/O-ASSISTANT
104 (68h)	Hardware info	G	STRUCT	Contains gateway hardware information (UINT): – count (number of the following entries) – CLOCK FREQUENCY (kHz) – MAIN FLASH (in kB) – MAIN FLASH SPEED (ns) – SECOND FLASH (kB) – RAM (kB), – RAM SPEED (ns), – RAM data WIDTH (bit), – SERIAL EEPROM (kbit) – RTC SUPPORT (in #) – AUTO SERVICE BSL SUPPORT (BOOL) – HDW SYSTEM

Object Instance 2

Table 5-34:
Object Instance
2, Gateway
Instance

Attr. No. dec. (hex.)	Attribute name	Get/ Set	Type	Description
109 (6Dh)	Status register 2	G	STRUCT	<p>Gateway-Status contains general gateway status information:</p> <p>Gateway</p> <ul style="list-style-type: none"> – Bit 15: "I/O Controller Error" The communication controller for the I/O-system is faulty. – Bit 14: "Force Mode Active Error" The Force Mode is activated. – Bit 13: reserved – Bit 12: reserved <p>Module bus</p> <ul style="list-style-type: none"> – Bit 11: "I/O Cfg Modified Error" The I/O-configuration has been changed and is now incompatible. – Bit 10: "I/O Communication Lost Error" No communication on the I/O module bus. <p>Voltage errors</p> <ul style="list-style-type: none"> – Bit 09: "U_{sys} too low" System supply voltage too low (< 18 VDC). – Bit 08: "U_{sys} too high" System supply voltage too high (> 30 VDC). – Bit 07: "U_L too low" Load voltage too low (< 18 VDC). – Bit 06: "U_L too high" Load voltage too high (> 30 VDC) – Bit 05: "I_{sys} too high" Overload of the system voltage supply. – Bit 04: reserved <p>Warnings</p> <ul style="list-style-type: none"> – Bit 03: "I/O Cfg Modified Warning" – Bit 02: reserved – Bit 01: reserved – Bit 00: "I/O Diags Active Warning" At least one I/O-module sends active diagnostics.
116 (74h)	Module diag summary	G	ARRAY OF STRUCT	<p>Contains the diagnostic information of all modules</p> <p>ARRAY OF STRUCT:</p> <p>USINT SLOT #: Indicates the slot number (module position) with diagnostic messages.</p> <p>BYTE SLOT FLAGS: Offers slot-related information. Bit 7 = 1 module missing Bit 6 = 1 wrong module plugged</p> <p>DWORD Diag: Contains the module diagnostic information. Module diagnostic bits that are not used are indicated by a "0".</p>

Table 5-34:
Object Instance
2, Gateway
Instance

Attr. No.	Attribute name	Get/ Set	Type	Description
dec. (hex.)				
138 (0x8A)	GW Status Register	Get/ Set	UINT	Allows to enable/disable the GW status register which is part of the input data.
139 (0x8B)	GW Control Register	Get/ Set	UINT	Allows to enable/disable the GW control register which is part of the output data.

5.3.3 Terminal Slot Class (VSC 101)

This class contains parameters and data for the base modules.



Note

Please refer to paragraph "Class Instance of the VSC", [page 5-26](#), for the description of the class instances for VSC.

Object Instance

Table 5-35:
Object Instances

Attr. No. dec. (hex.)	Attribute name	Get/ Set	Type	Description
100 (64h)	Max object attribute	G	USINT	Contains the number of the last object attribute to be implemented.
101 (65h)	Module present	G	BOOL	0 = module missing, base module without electronic module. 1 = module is plugged
102 (66h)	Slot state	G	ENUM USINT	NOT USED (0): A non-occupied slot is not taking part in process data traffic. It is not responding to data transmitted or received via I/O Connection Messages. PROCESSING (1): A BL20 module, recognized by the fieldbus is occupying a slot. Data transfer is taking place with the other fieldbus devices via I/O Connection Messages. ALLOCATED (2): The slot is not occupied, but has been reserved for a certain electronic module. The process data are set to 0. WRONG MODULE (3): The wrong module has been plugged in the slot, meaning, it supports process data lengths that were not previously defined or it is a different type of module. This false module will not be made known to the fieldbus and will not take part in process data traffic. The process data for this slot are set to 0.
103 (67h)	Module ID	G	DWORD	Contains the ID of the BL20 module.
104 (68h)	Module diag bit count	G	UINT	States the number of diagnostic bits of the module.
105 (69h)	Module param bit count	G	UINT	States the number of parameter bits of the module.
106 (6Ah)	Module diag bit count	G	UINT	States the number of input bits (produced bits) of the module.

<i>Table 5-35: Object Instances</i>	Attr. No. dec. (hex.)	Attribute name	Get/ Set	Type	Description
	107 (6Bh)	Module output bit count	G	UINT	States the number of output bits (consumed bits) of the module.
	108 (6Ch)	Module SUBMODE	G	USINT	Contains the Submode ID of the BL20 module.
	109 (6Dh)	Module group count	G	USINT	States the number of internal groups of the module.
	110 (6Eh)	Diag	G	ARRAY OF BYTE	Contains the diagnostic information of the module.
	111 (6Fh)	Param	G/S	ARRAY OF BYTE	Contains the parameters of the module.
	112 (70h)	Input	G	ARRAY OF BYTE	Contains the input data (produced data) of the module.
	113 (71h)	Output	G/S	ARRAY OF BYTE	Contains the output data (consumed data) of the module.
	114 (72h)	Referenced VSC	G	USINT	The VSC that represents this BL20 module. If this module is contained in the internal gateway library, then it is listed in a specific VSC that describes the typical attributes of the module.
	115 (73h)	Referenced VSC instance	G	USINT	The VSC Instance that represents this BL20 module. If this module is contained in the internal gateway library, then it is listed in a specific VSC that describes the typical attributes of the module.
	116 (74h)	Module registered index	G/S	ENUM USINT	Contains the index numbers specified in all the module lists.

5.3.4 Process Data Class (VSC102)

This class contains the process-relevant information.



Note

Please refer to paragraph "Class Instance of the VSC", [page 5-26](#), for the description of the class instances for VSC.

Object Instance 1, standard input process data (compressed)

Table 5-36: Object instance 1, standard input process data (compressed)

Attr. No. dec. (hex.)	Attribute name	Get/ Set	Type	Description
100 (64h)	Max object attribute	G	USINT	Contains the number of the last object attribute to be implemented.
101 (65h)	Attribute list	G	ARRAY OF USINT	List of all attributes that are supported by this Instance.
102 (66h)	Standard packed process input data	G	ARRAY OF WORD	Input process data, 16-bit aligned, compressed.
103 (67h)	Process data byte count	G	USINT	The number of bytes that are exchanged with this Instance.



Note

The following object instances of VSC 102 (Object instance 2 to Object instance 8) are only valid for gateways with Maj. Rev. ≥ 1.6.0.

Object Instance 2, standard output process data (compressed)

Table 5-37: Object instance 2, standard output process data (compressed)

Attr. No. dec. (hex.)	Attribute name	Get/ Set	Type	Description
100 (64h)	Max object attribute	G	USINT	Contains the number of the last object attribute to be implemented.
101 (65h)	Attribute list	G	ARRAY OF USINT	List of all attributes that are supported by this Instance.
102 (66h)	Standard packed process output data	G/S	ARRAY OF WORD	Output process data, 16-bit aligned, compressed.
103 (67h)	Process data byte count	G	USINT	The number of bytes that are exchanged with this Instance.

Object Instance 3, diagnostic instance

Table 5-38: Object Instance 3, diagnostic instance

Attr. No. dec. (hex.)	Attribute name	Get/ Set	Type	Description
104 (68h)	GW summarized diagnostics	G/S	BOOL	0 = disabled 1 = enabled: 1 bit of diagnosis per slot mapped at the end of the input data image (page 4-21). The actual data is loaded to the non-volatile memory of the gateway. Changes become valid after a start-up!
105 (69h)	GW scheduled diagnostics	G/S	BOOL	0 = disabled 1 = enabled: time sliced module related data block using a round robin mechanism (page 4-22). The actual data is loaded to the non-volatile memory of the gateway. Changes become valid after a start-up!
106 (6Ah)	reserved			
107 (6Bh)	I-MAP summarized diags	G	USINT	Contains the number of summarized diagnostic bytes. Changes become valid after a start-up!
108 (6Ch)	I-MAP scheduled diags	G	USINT	Contains the number of scheduled diagnostics bytes. Changes become valid after a start-up!

Object Instance 4, COS/CYCLIC instance

Table 5-39: Object Instance 4, COS/CYCLIC instance

Attr. No. dec. (hex.)	Attribute name	Get/ Set	Type	Description
104 (68h)	COS data mapping	G/S	ENUM USINT	Currently not supported

5.3.5 Power Supply Module Class (VSC103)

This class contains all the relevant information and parameters for the power distribution modules.



Note

Please refer to paragraph "Class Instance of the VSC", [page 5-26](#), for the description of the class instances for VSC.

Object Instance

Table 5-40:
Object instance

Attr. No. dec. (hex.)	Attribute name	Get/ Set	Type	Description
100 (64h)	Max object attribute	G	USINT	Contains the number of the last object attribute to be implemented.
101 (65h)	Module present	G	BOOL	0 = module missing, base module without electronic module. 1 = module is plugged
102 (66h)	Terminal slot number	G	USINT	The slot number of the base module belonging to the module (base module to the right of the gateway = No. 1). Corresponds to the respective Instance Number within the TERMINAL SLOT CLASS.
103 (67h)	Module ID	G	DWORD	Contains the module ID.
104 (68h)	Module order number	G	UDINT	Contains the ident number of the module.
105 (69h)	Module order name	G	SHORT STRING	Contains the name of the module, for example "BL20-PF-24VDC"
106 (6Ah)	Module revision	G	USINT	Contains the revision number of the module firmware.
107 (6Bh)	Module type ID	G	ENUM USINT	Describes the module type: – 0x00: type of module unknown (default) – 0x01: digital module – 0x11: analog voltage mod. – 0x12: analog current mod. – 0x13: analog RTD mod. – 0x14: analog THERMO mod. – 0x1F: analog volt./curr. mod. – 0x22: counter/incr. encoder 32bit – 0x28: SSI interface – 0x31: starter, mechanical – 0x32: starter, electrical – 0x41: RS232 mod. – 0x42: RS485/RS422 mod. – 0x51: CVI mod. – etc.

Table 5-40:
Object instance

Attr. No. dec. (hex.)	Attribute name	Get/ Set	Type	Description
108 (6Ch)	Module command interface	G/S	ARRAY	The control interface of the BL20 module. ARRAY OF: BYTE: Control byte sequence
109 (6Dh)	Module response interface	G	ARRAY	Response interface of the BL20 module. ARRAY OF: BYTE: Response byte sequence
110 (6Eh)	Diag size	G	UINT	Indicates the number of diagnostic bits of the module.
111 (6Fh)	Diag	G	WORD	Contains the diagnostic information of the module. WORD: Bit for bit assignment according to module specification.
112 (70h)	Module registered index	G	ENUM USINT	Contains the index numbers specified in all the module lists.

5.3.6 Digital Input Module Class (VSC104)

This Class contains all information and parameters for digital input modules.



Note

Please refer to paragraph "Class Instance of the VSC", [page 5-26](#), for the description of the class instances for VSC.

Object Instance

Table 5-41:
Object instance

Attr. No. dec. (hex.)	Attribute name	Get/ Set	Type	Description
100 (64h)	Max object attribute	G	USINT	Contains the number of the last object attribute to be implemented
101 (65h)	Module present	G	BOOL	0 = module missing, base module without electronic module. 1 = module is plugged
102 (66h)	Terminal slot number	G	USINT	The slot number of the base module belonging to the module (base module to the right of the gateway = No. 1). Corresponds to the respective Instance Number within the TERMINAL SLOT CLASS.
103 (67h)	Module ID	G	DWORD	Contains the module ID.
104 (68h)	Module order number	G	UDINT	Contains the ident number of the module.
105 (69h)	Module order name	G	SHORT STRING	Contains the name of the module, for example, "BL20-4DI-P".
106 (6Ah)	Module revision	G	USINT	Contains the revision number of the module firmware.
107 (6Bh)	Module type ID	G	ENUM USINT	Describes the module type: see attribute 107 (6Bh) on page 5-34
108 (6Ch)	Module command interface	G/S	ARRAY	The control interface of the BL20 module. ARRAY OF: BYTE: Control byte sequence
109 (6Dh)	Module response interface	G	ARRAY	Response interface of the BL20 module. ARRAY OF: BYTE: Response byte sequence
110 (6Eh)	Produced data size	G	UINT	Contains information concerning the range of data produced by the module.
111 (6Fh)	Produced data	G	DWORD	Contains the input data of the module. DWORD: Bit for bit assignment according to module specification.

<i>Table 5-41: Object instance</i>	Attr. No. dec. (hex.)	Attribute name	Get/ Set	Type	Description
	112 (70h)	Diag size	G	UINT	Contains information concerning the range of the diagnostic data of the module.
	113 (71h)	Diag	G/S	DWORD	Contains the diagnostic information of the module. DWORD: Bit for bit assignment according to module specification.
	114 (72h)	Param size	G	UINT	Contains information concerning the range of parameters of the module.
	115 (73h)	Params	G/S	DWORD	Contains the parameters of the module. DWORD: Bit for bit assignment according to module specification.
	116 (74h)	Module registered index	G	ENUM USINT	Contains the index numbers specified in all the module lists.

5.3.7 Digital Output Module Class (VSC105)

This Class contains all information and parameters for digital output modules.



Note

Please refer to paragraph "Class Instance of the VSC", [page 5-26](#), for the description of the class instances for VSC.

Object Instance

Table 5-42:
Object instance

Attr. No. dec. (hex.)	Attribute name	Get/ Set	Type	Description
100 (64h)	Max object attribute	G	USINT	Contains the number of the last object attribute to be implemented.
101 (65h)	Module present	G	BOOL	0 = module missing, base module without electronic module. 1 = module is plugged
102 (66h)	Terminal slot number	G	USINT	The slot number of the base module belonging to the module (base module to the right of the gateway = No. 1). Corresponds to the respective Instance Number within the TERMINAL SLOT CLASS.
103 (67h)	Module ID	G	DWORD	Contains the module ID.
104 (68h)	Module order number	G	UDINT	Contains the ident number of the module.
105 (69h)	Module order name	G	SHORT STRING	Contains the name of the module, for example, "BL20-4DO-0.5A-P".
106 (6Ah)	Module revision	G	USINT	Contains the revision number of the module firmware.
107 (6Bh)	Module type ID	G	ENUM USINT	Describes the module type: see attribute 107 (6Bh) on page 5-34
108 (6Ch)	Module command interface	G/S	ARRAY	The control interface of the BL20 module. ARRAY OF: BYTE: Control byte sequence
109 (6Dh)	Module response interface	G	ARRAY	Response interface of the BL20 module. ARRAY OF: BYTE: Response byte sequence
110 (6Eh)	Consumed data size	G	UINT	Contains information concerning the range of data consumed by the module.
111 (6Fh)	Consumed data	G	DWORD	Contains the output data of the module. DWORD: Bit for bit assignment according to module specification.

*Table 5-42:
Object instance*

Attr. No. dec. (hex.)	Attribute name	Get/ Set	Type	Description
112 (70h)	Diag size	G	UINT	Contains information concerning the range of the diagnostic data of the module.
113 (71h)	Diag	G/S	DWORD	Contains the diagnostic information of the module. DWORD: Bit for bit assignment according to module specification.
114 (72h)	Param size	G	UINT	Contains information concerning the range of parameters of the module.
115 (73h)	Params	G/S	DWORD	Contains the parameters of the module. DWORD: Bit for bit assignment according to module specification.
116 (74h)	Module registered index	G	ENUM USINT	Contains the index numbers specified in all the module lists.

5.3.8 Analog Input Voltage Module Class (VSC106)

This Class contains all information and parameters for analog input modules (voltage).



Note

Please refer to paragraph "Class Instance of the VSC", [page 5-26](#), for the description of the class instances for VSC.

Object Instance

Table 5-43:
Object instance

Attr. No. dec. (hex.)	Attribute name	Get/ Set	Type	Description
100 (64h)	Max object attribute	G	USINT	Contains the number of the last object attribute to be implemented.
101 (65h)	Module present	G	BOOL	0 = module missing, base module without electronic module. 1 = module is plugged
102 (66h)	Terminal slot number	G	USINT	The slot number of the base module belonging to the module (base module to the right of the gateway = No. 1). Corresponds to the respective Instance Number within the TERMINAL SLOT CLASS.
103 (67h)	Module ID	G	DWORD	Contains the module ID.
104 (68h)	Module order number	G	UDINT	Contains the ident number of the module.
105 (69h)	Module order name	G	SHORT STRING	Contains the name of the module, for example, "BL20-2AI-V".
106 (6Ah)	Module revision	G	USINT	Contains the revision number of the module firmware.
107 (6Bh)	Module type ID	G	ENUM USINT	Describes the module type: see attribute 107 (6Bh) on page 5-34
108 (6Ch)	Module command interface	G/S	ARRAY	The control interface of the BL20 module. ARRAY OF: BYTE: Control byte sequence
109 (6Dh)	Module response interface	G	ARRAY	Response interface of the BL20 module. ARRAY OF: BYTE: Response byte sequence
110 (6Eh)	Module registered index	G	ENUM USINT	Contains the index numbers specified in all the module lists.
111 (6Fh)	Number of supported channels	G	USINT	States the number of analog input channels supported by this module Instance.

Table 5-43: Object instance	Attr. No. dec. (hex.)	Attribute name	Get/ Set	Type	Description
	112 - 119 (70h - 77h)	Produced data	G	INT	Contains the data transmitted by the analog input module of channels No. 1 to No. 8. Only those channels are supported that are contained in attribute 111, "Number of supported channels". Attribute 112 contains the data for channel 1, attribute 119 for channel 8.
	120 - 127 (78h - 7Fh)	Diag data	G	BYTE	Contains the diagnostic data of the channels 1 to 8 of the analog input module. Only those channels are supported that are defined in attribute 111, "Number of supported channels". Attribute 120 contains the data for channel 1, attribute 127 for channel 8. BYTE diag: Bit0: 0 =ok 1 =measurement value range error Bit1 to 7: reserved
	128 - 135 (80h - 87h)	Mode para-meter data	G/S	BYTE	Contains the diagnostic data of the channels 1 to 8 of the analog input module. Only those channels are supported that are defined in attribute 111, "Number of supported channels". Attribute 128 contains the data for channel 1, attribute 135 for channel 8. BYTE mode: Bit0: Voltage mode: 0 =0....10V 1 =-10V....+10V Bit 1: Value representation 0 =Integer (15Bit + sign) 1 =12Bit (left-justified) Bit 2: Diagnostic: 0 = enable 1 = disable Bit 3 to 7: reserved

5.3.9 Analog Output Voltage Module Class (VSC107)

This Class contains all information and parameters for analog output modules (voltage).



Note

Please refer to paragraph "Class Instance of the VSC", [page 5-26](#), for the description of the class instances for VSC.

Object Instance

Table 5-44:
Object instance

Attr. No. dec. (hex.)	Attribute name	Get/ Set	Type	Description
100 (64h)	Max object attribute	G	USINT	Contains the number of the last object attribute to be implemented.
101 (65h)	Module present	G	BOOL	0 = module missing, base module without electronic module. 1 = module is plugged
102 (66h)	Terminal slot number	G	USINT	The slot number of the base module belonging to the module (base module to the right of the gateway = No. 1). Corresponds to the respective Instance Number within the TERMINAL SLOT CLASS.
103 (67h)	Module ID	G	DWORD	Contains the module ID.
104 (68h)	Module order number	G	UDINT	Contains the ident number of the module.
105 (69h)	Module order name	G	SHORT STRING	Contains the name of the module, for example, "BL20-2AO-V".
106 (6Ah)	Module revision	G	USINT	Contains the revision number of the module firmware.
107 (6Bh)	Module type ID	G	ENUM USINT	Describes the module type: see attribute 107 (6Bh) on page 5-34
108 (6Ch)	Module command interface	G/S	ARRAY	The control interface of the BL20 module. ARRAY OF: BYTE: Control byte sequence
109 (6Dh)	Module response interface	G	ARRAY	Response interface of the BL20 module. ARRAY OF: BYTE: Response byte sequence
110 (6Eh)	Module registered index	G	ENUM USINT	Contains the index numbers specified in all the module lists.
111 (6Fh)	Number of supported channels	G	USINT	States the number of analog input channels supported by this module Instance.

Table 5-44: Object instance	Attr. No. dec. (hex.)	Attribute name	Get/ Set	Type	Description
	112 - 119 (70h - 77h)	Consumed data	G	INT	Contains the data received by the analog output module of channels No. 1 to No. 8. Only those channels are supported that are contained in attribute 111, "Number of supported channels". Attribute 112 contains the data for channel 1, attribute 119 for channel 8.
	120 - 127 (78h - 7Fh)	Diag data	G	BYTE	Contains the diagnostic data of the channels 1 to 8 of the analog output module. Only those channels are supported that are defined in attribute 111, "Number of supported channels". Attribute 120 contains the data for channel 1, attribute 127 for channel 8. BYTE diag: Bit 0 to 7: reserved
	128 - 135 (80h - 87h)	Mode para-meter data	G/S	BYTE	Contains the diagnostic data of the channels 1 to 8 of the analog output module. Only those channels are supported that are defined in attribute 111, "Number of supported channels". Attribute 128 contains the data for channel 1, attribute 135 for channel 8. BYTE mode: Bit0: Voltage mode: 0 = 0....10V 1 = -10V....+10V Bit1: Value representation 0 = Integer (15Bit + sign) 1 = 12Bit (left-justified) Bit2 to 7: reserved
	136 - 143 (88h - 8Fh)	Fault value parameter data	G/S	INT	Contains the Fault Value-Definition of the channels 1 to 8 of the analog output modules. Only those channels are supported that are defined in attribute 111, "Number of supported channels". Attribute 136 contains the data for channel 1, attribute 143 for channel 8.

5.3.10 Analog Input Current Module Class (VSC108)

This Class contains all information and parameters for analog input modules (current).



Note

Please refer to paragraph "Class Instance of the VSC", [page 5-26](#), for the description of the class instances for VSC.

Object Instance

The Object Instances/ attributes of the analog input modules (current) correspond to those of the analog input modules (voltage). Differences are only to be found in the attributes no. 112 to 135 that concern the measurement ranges of the modules (current or voltage measurements).

Table 5-45:
Object Instance

Attr. No. dec. (hex.)	Attribute name	Get/ Set	Type	Description
112 - 119 (70h - 77h)	Produced data	G	INT	Contains the data transmitted by the analog input module of channels No. 1 to No. 8. Only those channels are supported that are contained in attribute 111, "Number of supported channels". Attribute 112 contains the data for channel 1, attribute 119 for channel 8.
120 - 127 (78h - 7Fh)	Diag data	G	BYTE	Contains the diagnostic data of the channels 1 to 8 of the analog input module. Only those channels are supported that are defined in attribute 111, "Number of supported channels". Attribute 120 contains the data for channel 1, attribute 127 for channel 8. BYTE diag: Bit 0: 0 = ok 1 = measurement value range error Bit 1: 0 =ok 1 =open circuit (only measurement range 4 to 20 mA) Bit 2 to 7: reserved

<i>Table 5-45: Object Instance</i>	Attr. No. dec. (hex.)	Attribute name	Get/ Set	Type	Description
	128 - 135 (80h - 87h)	Mode para-meter data	G/S	BYTE	Contains the diagnostic data of the channels 1 to 8 of the analog input module. Only those channels are supported that are defined in attribute 111, "Number of supported channels". Attribute 128 contains the data for channel 1, attribute 135 for channel 8. BYTE mode: Bit 0: Current mode: 0 = 0 to 20 mA 1 = 4 to 20 mA Bit 1: Value representation: 0 = Integer (15 Bit + sign) 1 = 12 Bit (left-justified) Bit 2: Diagnostic: 0 = enable 1 = disable Bit 3 to 7:reserved

5.3.11 Analog Output Current Module Class (VSC109)

This Class contains all information and parameters for analog output modules (current).



Note

Please refer to paragraph "Class Instance of the VSC", [page 5-26](#), for the description of the class instances for VSC.

Object Instance

The Object Instances/attributes of the analog output modules (current) correspond to those of the analog output modules (voltage). Differences are only to be found in the attributes no. 112 to 143 that concern the measurement ranges of the modules (current or voltage measurements).

Table 5-46:
Object Instance

Attr. No. dec. (hex.)	Attribute name	Get/ Set	Type	Description
112 - 119 (70h - 77h)	Consumed data	G	INT	Contains the data received by the analog output module of channels No. 1 to No. 8. Only those channels are supported that are contained in attribute 111, "Number of supported channels". Attribute 112 contains the data for channel 1, attribute 119 for channel 8.
120 - 127 (78h - 7Fh)	Diag data	G	BYTE	Contains the diagnostic data of the channels 1 to 8 of the analog output module. Only those channels are supported that are defined in attribute 111, "Number of supported channels". Attribute 120 contains the data for channel 1, attribute 127 for channel 8. BYTE diag: Bit 0 to 7: reserved
128 - 135 (80h - 87h)	Mode para-meter data	G/S	BYTE	Contains the diagnostic data of the channels 1 to 8 of the analog output module. Only those channels are supported that are defined in attribute 111, "Number of supported channels". Attribute 128 contains the data for channel 1, attribute 135 for channel 8. BYTE mode: Bit 0: Current mode: 0 = 0 to 20 mA 1 = 4 to 20 mA Bit 1: Value representation: 0 = Integer (15Bit + sign) 1 = 12Bit (left-justified) Bit 2 to 7:reserved

Attr. No. dec. (hex.)	Attribute name	Get/ Set	Type	Description
136 - 143 (88h - 8Fh)	Fault value parameter data	G/S	INT	Contains the Fault Value-Definition of the channels 1 to 8 of the analog output modules. Only those channels are supported that are defined in attribute 111, "Number of supported channels". Attribute 136 contains the data for channel 1, attribute 143 for channel 8.

5.3.12 Analog Input PT100/NI Module Class (VSC110)

This Class contains all information and parameters for analog input modules for PT100/NI sensors (current).



Note

Please refer to paragraph "Class Instance of the VSC", [page 5-26](#), for the description of the class instances for VSC.

Object Instance

Table 5-47:
Object instance

Attr. No. dec. (hex.)	Attribute name	Get/ Set	Type	Description
100 (64h)	Max object attribute	G	USINT	Contains the number of the last object attribute to be implemented.
101 (65h)	Module present	G	BOOL	0 = module missing, base module without electronic module. 1 = module is plugged
102 (66h)	Terminal slot number	G	USINT	The slot number of the base module belonging to the module (base module to the right of the gateway = No. 1). Corresponds to the respective Instance Number within the TERMINAL SLOT CLASS.
103 (67h)	Module ID	G	DWORD	Contains the module ID.
104 (68h)	Module order number	G	UDINT	Contains the ident number of the module.
105 (69h)	Module order name	G	SHORT STRING	Contains the name of the module, for example, "BL20-2AI-PT".
106 (6Ah)	Module revision	G	USINT	Contains the revision number of the module firmware.
107 (6Bh)	Module type ID	G	ENUM USINT	Describes the module type: see attribute 107 (6Bh) on page 5-34
108 (6Ch)	Module command interface	G/S	ARRAY	The control interface of the BL20 module. ARRAY OF: BYTE: Control byte sequence
109 (6Dh)	Module response interface	G	ARRAY	Response interface of the BL20 module. ARRAY OF: BYTE: Response byte sequence
110 (6Eh)	Module registered index	G	ENUM USINT	Contains the index numbers specified in all the module lists.
111 (6Fh)	Number of supported channels	G	USINT	States the number of analog input channels supported by this module Instance.

Table 5-47:
Object instance

Attr. No. dec. (hex.)	Attribute name	Get/ Set	Type	Description
112 - 119 (70h - 77h)	Produced data	G	INT	Contains the data received by the analog input module of channels No. 1 to No. 8. Only those channels are supported that are contained in attribute 111, "Number of supported channels". Attribute 112 contains the data for channel 1, attribute 119 for channel 8.
120 - 127 (78h - 7Fh)	Diag data	G	BYTE	Contains the diagnostic data of the channels 1 to 8 of the analog input module. Only those channels are supported that are defined in attribute 111, "Number of supported channels". Attribute 120 contains the data for channel 1, attribute 127 for channel 8. BYTE diag: Bit 0: 0 = ok 1 = measurement value range error Bit 1: 0 = ok 1 = open circuit Bit 2: 0 = ok 1 = short-circuit
128 - 135 (80h - 87h)	Mode parameter data	G/S	BYTE	Contains the diagnostic data of the channels 1 to 8 of the analog input module. Only those channels are supported that are defined in attribute 111, "Number of supported channels". Attribute 128 contains the data for channel 1, attribute 135 for channel 8. BYTE mode: Bit 0: Mains suppression 0 = 50 Hz mains suppression 1 = 60 Hz mains suppression Bit 1: value representation: 0 = Integer (15 Bit + sign) 1 = 12 Bit (left-justified) Bit 2: Diagnose: 0 = release 1 = block Bit 3: Channel: 0 = activate channel 1 = deactivate channel Bit 4: Measurement mode: 0 = 2-wire 1 = 3-wire Bit 5 to 7: reserved

Table 5-47:
Object instance

Attr. No. dec. (hex.)	Attribute name	Get/ Set	Type	Description
136 - 143 (88h - 8Fh)	Sensorpara-meter data	G/S	ENUM USINT	<p>Contains the sensor-specific parameter data of the channels 1 to 8 of the analog input module. Only those channels are supported that are defined in attribute 111, "Number of supported channels".</p> <p>Attribute 136 contains the data for channel 1, attribute 143 for channel 8.</p> <p>ENUM USINT: Element: 0: Pt100, -200...850 °C 1: Pt100, -200...150 °C 2: Ni100, -60...250 °C 3: Ni100, -60...150 °C 4: Pt200, -200...850 °C 5: Pt200, -200...150 °C 6: Pt500, -200...850 °C 7: Pt500, -200...150 °C 8: Pt1000, -200...850 °C 9: Pt1000, -200...150 °C 10: Ni1000, -60...250 °C 11: Ni1000, -60...150 °C 12: resistance: 0...100 Ω 13: resistance: 0...200 Ω 14: resistance: 0...400 Ω 15: resistance: 0...1000 Ω 16 to 255: reserved</p>

5.3.13 Analog Input THERMO Module Class (VSC111)

This Class contains all information and parameters for analog input modules for thermocouples.



Note

Please refer to paragraph "Class Instance of the VSC", [page 5-26](#), for the description of the class instances for VSC.

Object Instance

Table 5-48:
Object instance

Attr. No. dec. (hex.)	Attribute name	Get/ Set	Type	Description
100 (64h)	Max object attribute	G	USINT	Contains the number of the last object attribute to be implemented.
101 (65h)	Module present	G	BOOL	0 = module missing, base module without electronic module. 1 = module is plugged
102 (66h)	Terminal slot number	G	USINT	The slot number of the base module belonging to the module (base module to the right of the gateway = No. 1). Corresponds to the respective Instance Number within the TERMINAL SLOT CLASS.
103 (67h)	Module ID	G	DWORD	Contains the module ID.
104 (68h)	Module order number	G	UDINT	Contains the ident number of the module.
105 (69h)	Module order name	G	SHORT STRING	Contains the name of the module, for example, "BL20-2AI-TC".
106 (6Ah)	Module revision	G	USINT	Contains the revision number of the module firmware.
107 (6Bh)	Module type ID	G	ENUM USINT	Describes the module type: see attribute 107 (6Bh) on page 5-34
108 (6Ch)	Module command interface	G/S	ARRAY	The control interface of the BL20 module. ARRAY OF: BYTE: Control byte sequence
109 (6Dh)	Module response interface	G	ARRAY	Response interface of the BL20 module. ARRAY OF: BYTE: Response byte sequence
110 (6Eh)	Module registered index	G	ENUM USINT	Contains the index numbers specified in all the module lists.
111 (6Fh)	Number of supported channels	G	USINT	States the number of analog input channels supported by this module Instance.

Table 5-48:
Object instance

Attr. No. dec. (hex.)	Attribute name	Get/ Set	Type	Description
112 - 119 (70h - 77h)	Produced data	G	INT	Contains the data received by the analog input module of channels No. 1 to No. 8. Only those channels are supported that are contained in attribute 111, "Number of supported channels". Attribute 112 contains the data for channel 1, attribute 119 for channel 8.
120 - 127 (78h - 7Fh)	Diag data	G	BYTE	Contains the diagnostic data of the channels 1 to 8 of the analog input module. Only those channels are supported that are defined in attribute 111, "Number of supported channels". Attribute 120 contains the data for channel 1, attribute 127 for channel 8. BYTE diag: Bit 0: 0 = ok 1 = measurement value range error Bit 1: 0 =ok 1 =open circuit Bit 2 to 7:reserved
128 - 135 (80h - 87h)	Mode parameter data	G/S	BYTE	Contains the diagnostic data of the channels 1 to 8 of the analog input module. Only those channels are supported that are defined in attribute 111, "Number of supported channels". Attribute 128 contains the data for channel 1, attribute 135 for channel 8. BYTE mode: Bit 0: Mains suppression 0 = 50Hz mains suppression 1 = 60Hz mains suppression Bit 1: value representation: 0 = Integer (15Bit + sign) 1 = 12 Bit (left-justified) Bit 2: Diagnose: 0 = release 1 = block Bit 3:Channel: 0 = activate channel 1 = deactivate channel Bit 4 to 7: reserved

Table 5-48:
Object instance

Attr. No. dec. (hex.)	Attribute name	Get/ Set	Type	Description
136 - 143 (88h - 8Fh)	Sensor parameter data	G/S	ENUM USINT	<p>Contains the sensor-specific parameter data of the channels 1 to 8 of the analog input module. Only those channels are supported that are defined in attribute 111, "Number of supported channels".</p> <p>Attribute 136 contains the data for channel 1, attribute 143 for channel 8.</p> <p>ENUM USINT: Element: 0: Type K -270....1370 °C 1: Type B 100....1820 °C 2: Type E -270....1000 °C 3: Type J -210....1200 °C 4: Type N -270....1300 °C 5: Type R -50....1760 °C 6: Type S -50....1540 °C 7: Type T -270....400 °C 8: ± 50 mV 9: ± 100 mV 10: ± 500 mV 11: ± 1000 mV 12 to 255: reserved</p>

5.3.14 Counter Module Class (VSC112)

This Class contains all information and parameters concerning the counter module.



Note

Please refer to paragraph "Class Instance of the VSC", [page 5-26](#), for the description of the class instances for VSC.

Object Instance

Two different operating modes can be selected for the counter module: counter mode and measurement mode. Different attributes are supported depending on the operating mode selected, meaning, with certain attributes the operating mode has to be defined. The operating mode is determined in attribute 113.

Table 5-49:
Object instance

Attr. No. dec. (hex.)	Attribute name	Get/ Set	Type	Description
100 (64h)	Max object attribute	G	USINT	Contains the number of the last object attribute to be implemented.
101 (65h)	Module present	G	BOOL	0 = module missing, base module without electronic module. 1 = module is plugged
102 (66h)	Terminal slot number	G	USINT	The slot number of the base module belonging to the module (base module to the right of the gateway = No. 1). Corresponds to the respective Instance Number within the TERMINAL SLOT CLASS.
103 (67h)	Module ID	G	DWORD	Contains the module ID.
104 (68h)	Module order number	G	UDINT	Contains the ident number of the module.
105 (69h)	Module order name	G	SHORT STRING	Contains the name of the module, for example, "BL20-1RS232".
106 (6Ah)	Module revision number	G	USINT	Contains the revision number of the module firmware.
107 (6Bh)	Module type ID	G	ENUM USINT	Describes the module type: see attribute 107 (6Bh) on page 5-34
108 (6Ch)	Module command interface	G/S	ARRAY	The control interface of the BL20 module. ARRAY OF: BYTE: Control byte sequence
109 (6Dh)	Module response interface	G	ARRAY	Response interface of the BL20 module. ARRAY OF: BYTE: Response-byte sequence
110 (6Eh)	Module registered index	G	ENUM USINT	Contains the index numbers specified in all the module lists.

Table 5-49: Object instance	Attr. No. dec. (hex.)	Attribute name	Get/ Set	Type	Description
	111 (6Fh)	Number of supported channels	G	USINT	States the number of analog input channels supported by this module Instance.
	112 (70h)	Counter diag	G	WORD	<p>Contains the diagnostic data of the counter module. Bits 0 to 7 apply to the counter mode (CNT); bits 8 to 15 the counter mode (MSRM). CNT: Bit0: 0 = ok 1 = short-circuit/open circuit Bit1: 0 = ok 1 = short-circuit in sensor power supply 24 VDC Bit2: 0 = ok 1 = upper limit wrong Bit3: 0 = ok 1 = lower limit wrong Bit4: 0 = ok 1 = it is not permitted to invert the level of the digital input when using the latch retrigger function</p>
	112 (70h)	Counter diag	G	WORD	<p>CNT: Bit5: 0 = ok 1 = main count direction wrong Bit6: 0 = ok 1 = counter operating mode wrong Bit7: 0 = CNT Mode NOT active 1 = CNT Mode active MSRM: Bit 8: 0 = ok 1 = short- circuit/open circuit Bit9: 0 = ok 1 = short-circuit in sensor power supply 24 VDC Bit10: 0 = ok 1 = sensor pulse wrong Bit11: 0 = ok 1 = integration time wrong</p>

Table 5-49: Object instance	Attr. No. dec. (hex.)	Attribute name	Get/ Set	Type	Description
	112 (70h)	Counter diag	G	WORD	MSRM: Bit12: 0 = ok 1 = upper limit wrong Bit13: 0 = ok 1 = power limit wrong Bit14: 0 = ok 1 = measurement operating mode wrong Bit15: 0 = measurement Mode NOT active 1 = measurement Mode active
A Depend on the selected operating mode (CNT/MSRM) and are not supported in the other operating mode. Please refer to Attribute No. 113 BASIC MODE.	113 (71h)	Basic mode	G/S	ENUM USINT	Defines the operating mode of the counter module; hence, it must be written first. The definition of the operating mode in this attribute is the prerequisite for all further Instances and attributes in this class. Operating mode (basic mode): – 0: CNT: continuous count – 1: CNT: single-action count – 2: CNT: periodical count – 3: MSRM: frequency measurement – 4: MSRM: revolutions measurement – 5: MSRM: period duration measurement – 6 to 255: reserved
	114 (72h)	CNT gate function A	G/S	ENUM USINT	The gate function defines the counter’s reaction to the resetting of the internal release. Gate function: – 0: CNT: abort count procedure – 1: CNT: interrupt count procedure – 2 to 255: reserved
	115 (73h)	Digital input DI	G/S	ENUM USINT	Defines if the digital input of the module will be inverted or not. USINT digital input DI: – 0: normal – 1: inverted – 2 to 255:reserved

Table 5-49: Object instance	Attr. No. dec. (hex.)	Attribute name	Get/ Set	Type	Description
	116 (74h)	Function DI A	G/S	ENUM USINT	Defines the function of the digital input. Function DI: – 0: input – 1: HW gate – 2: CNT: latch retrigger when edge positive – 3: CNT: synchronization when edge positive – 4 to 255: reserved
AA Depend on the selected operating mode (CNT/MSRM) and are not supported in the other operating mode. Please refer to Attribute No. 113 BASIC MODE.	117 (75h)	CNT synchronization A	G/S	ENUM USINT	Defines the kind of synchronization. Synchronization: – 0: CNT: single-action – 1: CNT: periodical – 2 to 255: reserved
	118 (76h)	CNT main count direction A	G/S	ENUM USINT	Defines the main count direction: – 0: CNT: none – 1: CNT: up – 2: CNT: down – 3 to 255: reserved
	119 (77h)	Lower limit	G/S	DINT	Defines the lower limit of the module. The module reacts according to its parameterization on reaching or undershooting the lower limit.
	120 (78h)	Upper limit	G/S	DINT	Defines the upper limit of the module. The module reacts according to its parameterization on reaching or overshooting the upper limit.
	121 (79h)	MSRM integration A	G/S	USINT	Defines the integration time. Integration [*10ms]
	122 (7Ah)	CNT hysteresis A	G/S	USINT	Defines the hysteresis, meaning the differential threshold value. Hysteresis
	123 (7Bh)	CNT pulse duration A	G/S	USINT	Defines the pulse duration. Pulse duration [*2ms]
	124 (7Ch)	MSRM pulses per revolution A	G/S	UINT	Defines the number of pulses per revolution. Pulses per revolution
	125 (7Dh)	Fault value DO1	G/S	BOOL	Defines the substitute value of the digital output DO1. Fault value DO1: FALSE: 0 = off, 0V TRUE: 1 = on, 24V

Table 5-49:
Object instance

Attr. No. dec. (hex.)	Attribute name	Get/ Set	Type	Description
126 (7Eh)	Diagnostic DO1	G/S	BOOL	Defines if the diagnostic data of the DO1 are transmitted to the gateway. Diagnostic DO1: – FALSE: on Diagnostic data of the DO1 are being transmitted – TRUE: off Diagnostic data of the DO1 are not being transmitted
127 (7Fh)	Function DO1 A	G/S	ENUM USINT	Defines the function of the output DO1. Function DO1: 0: output 1: CNT: on when count value \geq reference value 2: CNT: on when count value \leq reference value 3: CNT: pulse when count value = reference value 4: MSRM: outside of limit 5: MSRM: below lower limit 6: MSRM: above upper limit 7 to 255:reserved
128 (80h)	CNT function DO2 A	G/S	ENUM USINT	Defines the function of the output DO2. This is not a physical output, meaning, the value from this output is read in the process input image only. Function DO2: – 0: output – 1: CNT: on when count value \geq reference value – 2: CNT: on when count value \leq reference value – 3: CNT: pulse when count value = reference value – 4 to 255:reserved
129 (81h)	Signal evaluation A	G/S	ENUM USINT	Defines the kind of signal evaluation. Signal evaluation: – 0: pulse and direction – 1: rotary sensor: single – 2: CNT: rotary sensor: double – 3: CNT: rotary sensor: fourfold – 4 to 255: reserved
130 (82h)	Sensor/input filter (A)	G/S	ENUM USINT	Defines the value of the input filter A. Sensor/input filter (A): – 0: 2.5 ms / 200 kHz – 1: 25 ms / 20k Hz – 2 to 255:reserved

ADepend on the selected operating mode (CNT/MSRM) and are not supported in the other operating mode. Please refer to Attribute No. 113 BASIC MODE.

Table 5-49:
Object instance

Attr. No. dec. (hex.)	Attribute name	Get/ Set	Type	Description
131 (83h)	Sensor/input filter (B)	G/S	ENUM USINT	Defines the value of the input filter B. Sensor/input filter (B): – 0: 2.5 ms / 200 kHz – 1: 25 ms / 20 kHz – 2 to 255: reserved
132 (84h)	Sensor/input filter (DI)	G/S	ENUM USINT	Defines the value of the input filter DI. Sensor/input filter (DI): 0: 2.5 ms / 200 kHz 1: 25 ms / 20 kHz 2 to 255: reserved
133 (85h)	Sensor (A)	G/S	ENUM USINT	Defines the sensor mode. ENUM USINT sensor (A): – 0: normal – 1: inverted – 2 to 255:reserved
134 (86h)	Direction input B	G/S	BOOL	States if the direction input B will be inverted. Direction input B: – FALSE: normal – TRUE: inverted
135 (87h)	Group diagnostics	G/S	BOOL	Defines if the group diagnostic will be transmitted to the gateway or not. Group diagnostic: – FALSE: release – TRUE: block
136 (88h)	On I/O connection fault	G/S	ENUM USINT	Defines the behavior of the module in the case of an I/O Connection Fault of the gateway. Behavior by I/O Connection Fault (parameter name of the counter: CPU/master STOP): – 0: turn off DO1 – 1: proceed with operating mode – 2: DO1 switch to Fault Value – 3: DO1 hold last value – 4 to 255:reserved

5.3.15 RS232 Module Class (VSC114)

This Class contains all information and parameters for RS232 modules.



Note

Please refer to paragraph "Class Instance of the VSC", [page 5-26](#), for the description of the class instances for VSC.

Object Instance

Table 5-50:
Object instance

Attr. No. dec. (hex.)	Attribute name	Get/ Set	Type	Description
100 (64h)	Max object attribute	G	USINT	Contains the number of the last object attribute to be implemented.
101 (65h)	Module present	G	BOOL	0 = module missing, base module without electronic module. 1 = module is plugged
102 (66h)	Terminal slot number	G	USINT	The slot number of the base module belonging to the module (base module to the right of the gateway = No. 1). Corresponds to the respective Instance Number within the TERMINAL SLOT CLASS.
103 (67h)	Module ID	G	DWORD	Contains the module ID.
104 (68h)	Module order number	G	UDINT	Contains the ident number of the module.
105 (69h)	Module order name	G	SHORT STRING	Contains the name of the module, for example, "BL20-1RS232".
106 (6Ah)	Module revision number	G	USINT	Contains the revision number of the module firmware.
107 (6Bh)	Module type ID	G	ENUM USINT	Describes the module type: see attribute 107 (6Bh) on page 5-34
108 (6Ch)	Module command interface	G/S	ARRAY	The control interface of the BL20 module. ARRAY OF: BYTE: Control byte sequence
109 (6Dh)	Module response interface	G	ARRAY	Response interface of the BL20 module. ARRAY OF: BYTE: Response-byte sequence
110 (6Eh)	Module registered index	G	ENUM USINT	Contains the index numbers specified in all the module lists.
111 (6Fh)	Number of supported channels	G	USINT	States the number of analog input channels supported by this module Instance.

Table 5-50:
Object instance

Attr. No. dec. (hex.)	Attribute name	Get/ Set	Type	Description
112 (70h)	RX byte count	G	USINT	Number of the valid bytes (0 to 7) in this data segment.
113 (71h)	RX count	G	USINT	This value is transferred together with every data segment of the process input data. The RX count values are sequential: 00->01->10->11->00... (decimal: 0->1->2->3->0...) Errors in this sequence show the loss of data segments.
114 (72h)	TX count acknowledge	G	USINT	This value is a copy of the value TX count. TX count has been transmitted together with the last data segment of the process output data. TX count acknowledge is an acknowledge for the successful transmission of the data segment with TRANSMIT count.
115 (73h)	Status	G	BOOL	0 = The communication with the data terminal equipment (DTE) is disturbed. A diagnostic message is generated if the parameter "Diagnostics" is set to "0/ release". The diagnostic data show the cause of the communication disturbance. The user has to set back this bit in the process output data by using STATRES. 1 = The communication with the data terminal equipment (DTE) is error free
116 (74h)	Process diagnostics data	G	BYTE	Contains the diagnostic information: The diagnostic data are part of the process input data, if ACTIVE MODE = 1 or "2bytes ctrl/status header" is set. Diagnostics messages: – Bit 0 to Bit 2: reserved – Bit 3: 0 = ok 1 = "parameter error": The set parameter values are not supported. – Bit 4: 0 = ok 1 = "hardware failure": The module has to be replaced, e.g. EEPROM or UART may be defect.

Table 5-50:
Object instance

Attr. No. dec. (hex.)	Attribute name	Get/ Set	Type	Description
116 (74h)	Process diagnostics data	G	BYTE	<ul style="list-style-type: none"> - Bit 5: 0 = ok 1 = "handshake error": The DTE connected to the module does not answer a XOFF or RTS handshake. This may cause a overflow in the internal receive-buffer. - Bit 6: 0 = ok 1 = "frame error": The module has to be parameterized to be adapted to the data structure of the connected DTE. A "frame error" occurs if the parameterization (number of data bits, stop bits, parity) is not correct. - Bit 7: 0 = ok 1 = "buffer overflow": Overflow in the RX-buffer. - Bit 8 to Bit 15: reserved
117 (75h)	RX data	G	ARRAY OF BYTE	Defines the receive-data (0...7).
118 (76h)	RX data and release	G	ARRAY OF BYTE	Defines the data received via RS232 (0...7) + acknowledge for reception
119 (77h)	TX BYTE count	G/S	USINT	Number of the valid user data bytes in this data segment. l
120 (78h)	TX count	G/S	USINT	<p>This value is transferred together with every data segment.</p> <p>The TX count values are sequential: 00->01->10->11->00... (decimal: 0->1->2->3->0...)</p> <p>Errors in this sequence show the loss of data segments.</p>
121 (79h)	RX count acknowledge	G/S	USINT	<p>This value is a copy of RX count.</p> <p>RX count has been transmitted together with the last data segment of the process input data.</p> <p>RX count acknowledge is an acknowledge for the successful transmission of the data segment with RX count.</p>

Table 5-50:
Object instance

Attr. No. dec. (hex.)	Attribute name	Get/ Set	Type	Description
122 (7Ah)	Status reset control	G/S	BOOL	<p>STATRES: This bit is set to reset the STAT bit in the process input data. With the change from 1 to 0 the status bit is reset (from 0 to 1). If this bit is 0, all changes in TRANSMIT BYTE count, TRANSMIT count and RECEIVE count acknowledge are ignored. Flushing the transmit-/ receive-buffer with Process control data (Attr. 123) is possible. If this bit is 1 or with the change from 0 to 1, the flushing of the transmit-/ receive-buffer with Process control data (Attr. 123) is not possible.</p>
123 (7Bh)	Process control data	G/S	BYTE	<p>Bit 0 = transmit-buffer flush, Bit 1 = receive-buffer flush</p>
124 (7Ch)	TX data	G/S	ARRAY OF BYTE	<p>Defines the transmit-data (0..7)</p>
125 (7Dh)	TX data and release	S	ARRAY OF BYTE	<p>Defines the data to be transmitted via RS232 (0..7) + transmission is released/ charged immediately</p>
126 (7Eh)	reserved			

Table 5-50:
Object instance

Attr. No. dec. (hex.)	Attribute name	Get/ Set	Type	Description
127 (7Fh)	Diagnostics	G	WORD	<p>Contains the diagnostic messages (low byte):</p> <p>Diagnostics messages:</p> <ul style="list-style-type: none"> - Bit 0 to Bit 2: reserved - Bit 3: <ul style="list-style-type: none"> 0 = ok 1 = "parameter error": The set parameter values are not supported. - Bit 4: <ul style="list-style-type: none"> 0 = ok 1 = "hardware failure": The module has to be replaced, e.g. EEPROM or UART may be defect. - Bit 5: <ul style="list-style-type: none"> 0 = ok 1 = "handshake error": The DTE connected to the module does not answer a XOFF or RTS handshake. This may cause a overflow in the internal receive-buffer. - Bit 6: <ul style="list-style-type: none"> 0 = ok 1 = "frame error": The module has to be parameterized to be adapted to the data structure of the connected DTE. A "frame error" occurs if the parameterization (number of data bits, stop bits, parity) is not correct. - Bit 7: <ul style="list-style-type: none"> 0 = ok 1 = "buffer overflow": Overflow in the RX-buffer. - High byte: reserved
128 (80h)	Active mode	G/S	BOOL	<p>0 = "1byte ctrl/status header": The diagnostic data are not part of the process input data, 7 bytes of user data are available.</p> <p>1 = "2byte ctrl/status header": The diagnostic data are part of the process input data, 6 bytes of user data are available.</p>

Table 5-50:
Object instance

Attr. No. dec. (hex.)	Attribute name	Get/ Set	Type	Description
129 (81h)	Bit rate	G/S	ENUM USINT	Used to set the baudrate for the gateway: 0= reserved, 1 = 300 bps 2 = 600 bps 3 = 1200 bps 4 = 2400 bps 5 = 4800 bps 6 = 9600 bps 7 = 14400 bps 8 = 19200 bps 9 = 28800 bps 10 = 38400 bps 11 = 57600 bps 12 = 115200 bps ... 15 = reserved)
130 (82h)	Disable diagnostics	G/S	BOOL	0 = "released": The diagnostic function is activated. 1 = "blocked": The diagnostic function is deactivated.
131 (83h)	Flow control	G/S	ENUM USINT	0 = "off": data flow control is deactivated 1 = XON/XOFF Software-handshake is activated 2 = RTS/CTS Hardware-handshake is activated 3: reserved
132 (84h)	Data width	G/S	ENUM USINT	0 = "7 bits" 1 = "8 bits"
133 (85h)	Parity	G/S	ENUM USINT	0 = "none" 1 = "odd" The number of the bits set to 1 is odd (incl. data and parity bit). 2 = "even" The number of the bits set to 1 is even (incl. data and parity bit).
134 (86h)	Stop	G/S	ENUM USINT	Number of the stop bits. 0 = "1 bit" 1 = "2 bits"

*Table 5-50:
Object instance*

Attr. No. dec. (hex.)	Attribute name	Get/ Set	Type	Description
135 (87h)	XON character	G/S	USINT	XON character This sign is used to start the data transfer to the data terminal equipment (DTE) with the activation of the software handshake. 0 - 255 default: 17/ 11h
136 (88h)	XOFF character	G/S	USINT	XOFF character This sign is used to stop the data transfer to the data terminal equipment (DTE) with the activation of the software handshake. (0 - 255) default: 19/ 13h

5.3.16 RS485/422 Module Class (VSC115)

This Class contains all information and parameters for RS485/422 modules.



Note

Please refer to paragraph "Class Instance of the VSC", [page 5-26](#), for the description of the class instances for VSC.

Object Instance

Table 5-51:
Object instance

Attr. No. dec. (hex.)	Attribute name	Get/ Set	Type	Description
100 (64h)	Max object attribute	G	USINT	Contains the number of the last object attribute to be implemented.
101 (65h)	Module present	G	BOOL	0 = module missing, base module without electronic module. 1 = module is plugged
102 (66h)	Terminal slot number	G	USINT	The slot number of the base module belonging to the module (base module to the right of the gateway = No. 1). Corresponds to the respective Instance Number within the TERMINAL SLOT CLASS.
103 (67h)	Module ID	G	DWORD	Contains the module ID.
104 (68h)	Module order number	G	UDINT	Contains the ident number of the module.
105 (69h)	Module order name	G	SHORT STRING	Contains the name of the module, for example, "BL20-1RS485/422".
106 (6Ah)	Module revision number	G	USINT	Contains the revision number of the module firmware.
107 (6Bh)	Module type ID	G	ENUM USINT	Describes the module type: see attribute 107 (6Bh) on page 5-34
108 (6Ch)	Module command interface	G/S	ARRAY	The control interface of the BL20 module. ARRAY OF: BYTE: Control byte sequence
109 (6Dh)	Module response interface	G	ARRAY	Response interface of the BL20 module. ARRAY OF: BYTE: Response-byte sequence
110 (6Eh)	Module registered index	G	ENUM USINT	Contains the index numbers specified in all the module lists.
111 (6Fh)	Number of supported channels	G	USINT	States the number of analog input channels supported by this module Instance.

Table 5-51:
Object instance

Attr. No. dec. (hex.)	Attribute name	Get/ Set	Type	Description
112 (70h)	RX byte count	G	USINT	Number of the valid bytes (0 to 7) in this data segment.
113 (71h)	RX count	G	USINT	This value is transferred together with every data segment of the process input data. The RX count values are sequential: 00->01->10->11->00... (decimal: 0->1->2->3->0...) Errors in this sequence show the loss of data segments.
114 (72h)	TX count acknowledge	G	USINT	This value is a copy of the value TX count. TX count has been transmitted together with the last data segment of the process output data. TX count acknowledge is an acknowledge for the successful transmission of the data segment with TRANSMIT count.
115 (73h)	Status	G	BOOL	0 = The communication with the data terminal equipment (DTE) is disturbed. A diagnostic message is generated if the parameter "Diagnostics" is set to "0/ release". The diagnostic data show the cause of the communication disturbance. The user has to set back this bit in the process output data by using STATRES. 1 = The communication with the data terminal equipment (DTE) is error free,
116 (74h)	Process diagnostics data	G	BYTE	Contains the diagnostic information: The diagnostic data are part of the process input data, if ACTIVE MODE = 1 or "2bytes ctrl/status header" is set. Diagnostics messages: – Bit 0 to Bit 2: reserved – Bit 3: 0 = ok 1 = "parameter error": The set parameter values are not supported. – Bit 4: 0 = ok 1 = "hardware failure": The module has to be replaced, e.g. EEPROM or UART may be defect.

Table 5-51:
Object instance

Attr. No. dec. (hex.)	Attribute name	Get/ Set	Type	Description
116 (74h)	Process diagnostics data	G	BYTE	<ul style="list-style-type: none"> - Bit 5: 0 = ok 1 = "handshake error": The DTE connected to the module does not answer a XOFF or RTS handshake. This may cause a overflow in the internal receive-buffer. - Bit 6: 0 = ok 1 = "frame error": The module has to be parameterized to be adapted to the data structure of the connected DTE. A "frame error" occurs if the parameterization (number of data bits, stop bits, parity) is not correct. - Bit 7: 0 = ok 1 = "buffer overflow": Overflow in the RX-buffer. - Bit 8 to Bit 15: reserved
117 (75h)	RX data	G	ARRAY OF BYTE	Defines the receive-data (0...7).
118 (76h)	RX data and release	G	ARRAY OF BYTE	Defines the data received via RS485/422 (0...7) + acknowledge for reception
119 (77h)	TX byte count	G/S	USINT	Number of the valid user data bytes in this data segment. l
120 (78h)	TX count	G/S	USINT	<p>This value is transferred together with every data segment.</p> <p>The TX count values are sequential: 00->01->10->11->00... (decimal: 0->1->2->3->0...)</p> <p>Errors in this sequence show the loss of data segments.</p>
121 (79h)	RX count acknowledge	G/S	USINT	<p>This value is a copy of RX count.</p> <p>RX count has been transmitted together with the last data segment of the process input data.</p> <p>RX count acknowledge is an acknowledge for the successful transmission of the data segment with RX count.</p>

Table 5-51:
Object instance

Attr. No. dec. (hex.)	Attribute name	Get/ Set	Type	Description
122 (7Ah)	Status reset control	G/S	BOOL	<p>STATRES: This bit is set to reset the STAT bit in the process input data. With the change from 1 to 0 the status bit is reset (from 0 to 1). If this bit is 0, all changes in TRANSMIT BYTE count, TRANSMIT count and RECEIVE count acknowledge are ignored. Flushing the transmit-/ receive-buffer with Process control data (Attr. 123) is possible. If this bit is 1 or with the change from 0 to 1, the flushing of the transmit-/ receive-buffer with Process control data (Attr. 123) is not possible.</p>
123 (7Bh)	Process control data	G/S	BYTE	Bit 0 = transmit-buffer flush, Bit 1 = receive-buffer flush
124 (7Ch)	TX data	G/S	ARRAY OF BYTE	Defines the transmit-data (0...7)
125 (7Dh)	TX data and release	S	ARRAY OF BYTE	Defines the data to be transmitted via RS485/422 (0...7) + transmission is released/ charged immediately
126 (7Eh)	reserved			

Table 5-51: Object instance	Attr. No. dec. (hex.)	Attribute name	Get/ Set	Type	Description
	127 (7Fh)	Diagnostics	G	WORD	Contains the diagnostic messages (low byte): Diagnostics messages: – Bit 0 to Bit 2: reserved – Bit 3: 0 = ok 1 = "parameter error": The set parameter values are not supported. – Bit 4: 0 = ok 1 = "hardware failure": The module has to be replaced, e.g. EEPROM or UART may be defect. – Bit 5: 0 = ok 1 = "handshake error": The DTE connected to the module does not answer a XOFF or RTS handshake. This may cause a overflow in the internal receive-buffer. – Bit 6: 0 = ok 1 = "frame error": The module has to be parameterized to be adapted to the data structure of the connected DTE. A "frame error" occurs if the parameterization (number of data bits, stop bits, parity) is not correct. – Bit 7: 0 = ok 1 = "buffer overflow": Overflow in the RX-buffer. – High byte: reserved
	128 (80h)	Active mode	G/S	BOOL	0 = "1 byte ctrl/status header": The diagnostic data are not part of the process input data, 7 bytes of user data are available. 1 = "2byte ctrl/status header": The diagnostic data are part of the process input data, 6 bytes of user data are available.

Table 5-51:
Object instance

Attr. No. dec. (hex.)	Attribute name	Get/ Set	Type	Description
129 (81h)	Bit rate	G/S	ENUM USINT	Used to set the baudrate for the gateway: 0 = reserved, 1 = 300 bps 2 = 600 bps 3 = 1200 bps 4 = 2400 bps 5 = 4800 bps 6 = 9600 bps 7 = 14400 bps 8 = 19200 bps 9 = 28800 bps 10 = 38400 bps 11 = 57600 bps 12 = 115200 bps ... 15 = reserved)
130 (82h)	Disable diagnostics	G/S	BOOL	0 = "released": The diagnostic function is activated. 1 = "blocked": The diagnostic function is deactivated.
131 (83h)	Flow control	G/S	ENUM USINT	0 = "off": data flow control is deactivated 1 = XON/XOFF Software-handshake is activated 2 = RTS/CTS Hardware-handshake is activated 3 = reserved
132 (84h)	Data width	G/S	ENUM USINT	0 = "7 bits" 1 = "8 bits"
133 (85h)	Parity	G/S	ENUM USINT	0 = "none" 1 = "odd" The number of the bits set to 1 is odd (incl. data and parity bit). 2 = "even" The number of the bits set to 1 is even (incl. data and parity bit).
134 (86h)	Stop	G/S	ENUM USINT	Number of the stop bits. 0 = "1 bit" 1 = "2 bits"

<i>Table 5-51: Object instance</i>	Attr. No.	Attribute name	Get/ Set	Type	Description
dec. (hex.)					
135 (87h)	XON character	G/S	USINT	XON character This sign is used to start the data transfer to the data terminal equipment (DTE) with the activation of the software handshake. 0 - 255 default: 17/ 11h	
136 (88h)	XOFF character	G/S	USINT	XOFF character This sign is used to stop the data transfer to the data terminal equipment (DTE) with the activation of the software handshake. (0 - 255) default: 19/ 13h	
137 (89h)	RSxxx mode	G/S	ENUM USINT	0 = "RS422": Parameterization as 422 1 = "RS485": Parameterization as 485	

5.3.17 SSI Module Class (VSC116)

This Class contains all information and parameters for SSI- modules.



Note

Please refer to paragraph "Class Instance of the VSC", [page 5-26](#), for the description of the class instances for VSC.

Object Instance

Table 5-52:
Object instance

Attr. No. dec. (hex.)	Attribute name	Get/ Set	Type	Description
100 (64h)	Max object attribute	G	USINT	Contains the number of the last object attribute to be implemented.
101 (65h)	Module present	G	BOOL	0 = module missing, base module without electronic module. 1 = module is plugged
102 (66h)	Terminal slot number	G	USINT	The slot number of the base module belonging to the module (base module to the right of the gateway = No. 1). Corresponds to the respective Instance Number within the TERMINAL SLOT CLASS.
103 (67h)	Module ID	G	DWORD	Contains the module ID.
104 (68h)	Module order number	G	UDINT	Contains the ident number of the module.
105 (69h)	Module order name	G	SHORT STRING	Contains the name of the module, for example, "BL20-1SSI".
106 (6Ah)	Module revision number	G	USINT	Contains the revision number of the module firmware.
107 (6Bh)	Module type ID	G	ENUM USINT	Describes the module type: see attribute 107 (6Bh) on page 5-34
108 (6Ch)	Module command interface	G/S	ARRAY	The control interface of the BL20 module. ARRAY OF: BYTE: Control byte sequence
109 (6Dh)	Module response interface	G	ARRAY	Response interface of the BL20 module. ARRAY OF: BYTE: Response-byte sequence
110 (6Eh)	Module registered index	G	ENUM USINT	Contains the index numbers specified in all the module lists.
111 (6Fh)	Number of supported channels	G	USINT	States the number of analog input channels supported by this module Instance.

Table 5-52:
Object instance

Attr. No. dec. (hex.)	Attribute name	Get/ Set	Type	Description
112 (70h)	Diagnostics and status	G	WORD	<p>Bit 0:</p> <ul style="list-style-type: none"> - 0 = No enabled status signal is active (SSI_STSx = 0). - 1 = "group diagnostics" At least one enabled status signal is active (SSI_STSx = 1). <p>Bit 1:</p> <ul style="list-style-type: none"> - 0 = SSI encoder signal present. - 1 = "SSI error/open circuit" SSI encoder signal faulty. (e.g. due to a cable break). <p>Bit 2:</p> <ul style="list-style-type: none"> - 0 = A comparison of the register contents has produced the following result: (REG_SSI_POS) ≤ (REG_UPPER_LIMIT) - 1 = "error POS > UPPER LIMIT" A comparison of the register contents has produced the following result: (REG_SSI_POS) > (REG_UPPER_LIMIT)
112 (70h)	Diagnostics and status	G	WORD	<p>Bit 3:</p> <ul style="list-style-type: none"> - 0 = A comparison of the register contents has produced the following result: (REG_SSI_POS) ≥ (REG_LOWER_LIMIT) - 1 = "error POS < LOWER LIMIT" A comparison of the register contents has produced the following result: (REG_SSI_POS) < (REG_LOWER_LIMIT) <p>Bit 4:</p> <ul style="list-style-type: none"> - 0 = The parameter set of the module has been accepted. - 1 = "parameterization error" Operation of the module is not possible with the present parameter set. <p>Bit 5 to 6: reserved</p> <p>Bit 7:</p> <ul style="list-style-type: none"> - 0 = The SSI encoder is read cyclically. - 1 = "SSI communication suspended" Communication with the SSI encoder is stopped as STOP = 1 (process output) or ERR_PARA = 1.

Table 5-52:
Object instance

Attr. No. dec. (hex.)	Attribute name	Get/ Set	Type	Description
112	Diagnostics and status	G	WORD	<p>Bit 8:</p> <ul style="list-style-type: none"> - 0 = A comparison of the register contents has produced the following result: $(REG_SSI_POS) \neq (REG_CMP1)$ - 1 = "CMP1 register value matches POS" A comparison of the register contents has produced the following result: $(REG_SSI_POS) = (REG_CMP1)$ <p>Bit 9:</p> <ul style="list-style-type: none"> - 0 = Default status, i.e. the register contents have not yet matched $(REG_SSI_POS) = (REG_CMP1)$ since the last reset. - 1 = "CMP1 flag set" The contents of the registers match: $(REG_SSI_POS) = (REG_CMP1)$. This marker must be reset with bit 9 of the "Control" attribute.
112	Diagnostics and status	G	WORD	<p>Bit 10:</p> <ul style="list-style-type: none"> - 0 = A comparison of the register contents has produced the following result: $(REG_SSI_POS) < (REG_CMP1)$ - 1 = "POS \geq CMP1 register value" A comparison of the register contents has produced the following result: $(REG_SSI_POS) \geq (REG_CMP1)$ <p>Bit 11:</p> <ul style="list-style-type: none"> - 0 = A comparison of the register contents has produced the following result: $(REG_SSI_POS) \neq (REG_CMP2)$ - 1 = "CMP2 register value matches POS" A comparison of the register contents has produced the following result: $(REG_SSI_POS) = (REG_CMP2)$

Table 5-52:
Object instance

Attr. No. dec. (hex.)	Attribute name	Get/ Set	Type	Description
112	Diagnostics and status	G	WORD	<p>Bit 12:</p> <ul style="list-style-type: none"> - 0 = Default status, i.e. the register contents have not yet matched (REG_SSI_POS) = (REG_CMP2) since the last reset. - 1 = "CMP2 flag set" The contents of the registers match: (REG_SSI_POS) = (REG_CMP2). This marker must be reset with bit 12 of the "Control" attribute. <p>Bit 13:</p> <ul style="list-style-type: none"> - 0 = A comparison of the register contents has produced the following result: (REG_SSI_POS) < (REG_CMP2) - 1 = "POS ≥ CMP2 register value". A comparison of the register contents has produced the following result: (REG_SSI_POS) ≥ (REG_CMP2) <p>Bit 14:</p> <ul style="list-style-type: none"> - 0 = The SSI encoder values are incremented or the values are constant. - 1 = "counting downwards" The SSI encoder values are decremented.
112	Diagnostics and status	G	WORD	<p>Bit 15:</p> <ul style="list-style-type: none"> - 0 = The SSI encoder values are decremented or the values are constant. - 1 = "counting upwards" The SSI encoder values are incremented.
113 (71h)	Result write operation	G		<p>Bit 0 to 5: reserved</p> <p>Bit 6:</p> <ul style="list-style-type: none"> - 0 = No modification of the data in the register bank by process output, i.e. WRITE OPERATION = 0. A write job would be accepted with the next telegram of process output data. (handshake for data transmission to the register.) - 1 = "control register write acknowledged" A modification of the register contents by a process output was initiated, i.e. WRITE OPERATION = 1. A write job would not be accepted with the next telegram of process output data.

Table 5-52:
Object instance

Attr. No. dec. (hex.)	Attribute name	Get/ Set	Type	Description
113 (71h)	Result write operation	G		<p>Bit 7:</p> <ul style="list-style-type: none"> - 0 = The writing of user data for process output to the register addressed with "Address write register" in the process output data could not be executed. - 1 = "control register write accepted" The writing of user data for process output to the register addressed with "Address write register" in the process output data could be executed successfully.
114 (72h)	Result read operation	G	BYTE	<p>Bit 0 to 6: reserved</p> <hr/> <p>Bit 7:</p> <ul style="list-style-type: none"> 0 = The reading of the register stated in "Address read register" was accepted and executed. The content of the register is located in "Value read register". 1 = "register read operation aborted" The reading of the register stated in "Address read register" was not accepted. "Value read register" is zero.
115 (73h)	Address read register	G	UINT	Address of the input register with contents stated in "Value read register" when "Result read operation" = 0.
116 (74h)	Value read register	G	DWORD	Content of the register to be read if "Result read operation" = 0. If "Result read operation" = 1, "Value read register" = 0.
117 (75h)	Control	G/S	WORD	<p>Bit 0 to 6: reserved</p> <p>Bit 7:</p> <ul style="list-style-type: none"> - 0 = Request to read the SSI encoder cyclically - 1 = "suspend communication requested" Request to interrupt communication with the encoder <p>Bit 8:</p> <ul style="list-style-type: none"> - 0 = Default status, i.e. the data bits 8 to 10 of the "Diagnostics and status" attribute always have the value 0, irrespective of the actual SSI encoder value. - 1 = "compare/flag CMP1 active" Comparison active, i.e. the data bits 8 to 10 of the "Diagnostics and status" attribute always have a value based on the result of the comparison with the actual SSI encoder value.

Table 5-52:
Object instance

Attr. No. dec. (hex.)	Attribute name	Get/ Set	Type	Description
117 (75h)	Control	G/S	WORD	<p>Bit 9: – 0 = Default status, i.e. reset of Bit 9 of the "Diagnostics and status" attribute not active. – 1 = "clear CMP1 flag" Reset of bit 9 of the "Diagnostics and status" attribute active.</p> <p>Bit 10: reserved</p> <p>Bit 11: 0 = Default status, i.e. the data bits 11 to 13 of the "Diagnostics and status" attribute always have the value 0, irrespective of the actual SSI encoder value. 1 = "compare/flag CMP2 active" Comparison active, i.e. the data bits 11 to 13 of the "Diagnostics and status" attribute always have a value based on the result of the comparison with the actual SSI encoder value.</p> <p>Bit 12: 0 = Default status, i.e. no reset of Bit 12 of the "Diagnostics and status" attribute active. 1 = "clear CMP2 flag" Reset of bit 12 of the "Diagnostics and status" attribute active.</p> <p>Bit 13 to 15: reserved</p>
118 (76h)	Address read register	G/S	UINT	Address of the register with contents stated in "Value read register" when "Result read operation" 7 = 0.
119 (77h)	Address write register	G/S	UINT	Address of the register to be written with "Value write register".
120 (78h)	Value write register	G/S	DWORD	Value to be written to the register with the address stated at "Address write register".
121 (79h)	Write operation	G/S	BOOL	<p>0 = Default status, i.e. there is no request to overwrite the content of the register address stated at "Address write register" with "Value write register". Bit 6 of the "Result write operation" attribute is reset (=0) if necessary. 1 = Request to overwrite the content of the register at the address "Address write register" with "Value write register".</p>
122 (7Ah)	Write register and execute	S	STRUCTOF UINT DWORD	<p>The structure contains both parts: – Address of the register to be written. – Value to be written. The write operation is executed without checking whether a write job is already present.</p>

Table 5-52:
Object instance

Attr. No. dec. (hex.)	Attribute name	Get/ Set	Type	Description
123 (7Bh)	Diagnostics	G	WORD	<p>Bit 0:</p> <ul style="list-style-type: none"> - 0 = No enabled status signal is active (SSI_STSx = 0). - 1 = "group diagnostics" At least one enabled status signal is active (SSI_STSx = 1). <p>Bit 1:</p> <ul style="list-style-type: none"> 0 = SSI encoder signal present. - 1 = "SSI error/open circuit" SSI encoder signal faulty. (e.g. due to a cable break). <p>Bit 2:</p> <ul style="list-style-type: none"> - 0 = A comparison of the register contents has produced the following result: (REG_SSI_POS) ≤ (REG_UPPER_LIMIT) - 1 = "error POS > UPPER LIMIT" A comparison of the register contents has produced the following result: (REG_SSI_POS) > (REG_UPPER_LIMIT) <p>Bit 3:</p> <ul style="list-style-type: none"> - 0 = A comparison of the register contents has produced the following result: (REG_SSI_POS) ≥ (REG_LOWER_LIMIT) - 1 = "error POS < LOWER LIMIT" A comparison of the register contents has produced the following result: (REG_SSI_POS) < (REG_LOWER_LIMIT)
123 (7Bh)	Diagnostics	G	WORD	<p>Bit 4:</p> <ul style="list-style-type: none"> - 0 = The parameter set of the module has been accepted. - 1 = "parameterization error" Operation of the module is not possible with the present parameter set. <p>Bit 5 to 15: reserved</p>
124 (7Ch)	Check mode	G/S	WORD	<p>Bit 0 to 4: reserved</p> <hr/> <p>Bit 5:</p> <ul style="list-style-type: none"> 0 = ZERO test of data cable. 1 = "disable SSI error detection" After the last valid bit, a ZERO test of the data cable is not carried out. <hr/> <p>Bit 6 to 15: reserved</p>

Table 5-52: Object instance	Attr. No. dec. (hex.)	Attribute name	Get/ Set	Type	Description
A INVALID_BITS: INVALID BITS MSB + INVALID BITS LSB	125 (7Dh)	Invalid bits LSB A	G/S	USINT	Number of invalid bits on the LSB side of the position value supplied by the SSI encoder. The meaningful word width of the position value transferred to the module bus master is as follows: FRAME LENGTH - INVALID BITS MSB - INVALID BITS LSB. The invalid bits on the LSB side are removed by shifting the position value to the right, starting with the LSB. (Default 0 Bit = 0hex). INVALID BITS MSB + INVALID BITS LSB must always be less than FRAME LENGTH.
	126 (7Eh)	Bit rate		ENUM USINT	0 = "1 Mbps" 1 = "500 kbps" 2 = "250 kbps" 3 = "100 kbps" 4 = "125 kbps" 5 = "83 kbps" 6 = "71 kbps" 7 = "62.5 kbps" 8 to 15: reserved
	128 (80h)	Frame length	G/S	USINT	Number of bits of the SSI data frame. FRAME LENGTH must always be greater than INVALID_BITS. A Default: 25 = 19hex
	129 (81h)	Kind of coding SSI	G/S	BOOL	0 = "Binary code" 1 = "GRAY code"
	130 (82h)	Invalid bits MSB	G/S	USINT	Number of invalid bits on the MSB side of the position value supplied by the SSI encoder. The meaningful word width of the position value transferred to the module bus master is as follows: FRAME LENGTH - INVALID BITS MSB - INVALID BITS LSB. The invalid bits on the MSB side are zeroed by masking the position value. I NVALID BITS MSB + INVALID BITS LSB must always be less than FRAME LENGTH. Default: 0 = 0hex

5.3.18 Digital Versatile Module Class (VSC117)

This class contains all information and parameters for digital versatile modules.



Attention

In this class, chosen parameter options can only be deactivated by activating another option of this parameter.



Note

Please refer to paragraph "Class Instance of the VSC", [page 5-26](#), for the description of the class instances for VSC.

Object Instance

Table 5-53:
Object instance

Attr. No. dec. (hex.)	Attribute name	Get/ Set	Type	Description
100 (64h)	Max object attribute	G	USINT	Contains the number of the last object attribute to be implemented.
101 (65h)	Module present	G	BOOL	0 = module missing, base module without electronic module. 1 = module is plugged
102 (66h)	Terminal slot number	G	USINT	The slot number of the base module belonging to the module (base module to the right of the gateway = No. 1). Corresponds to the respective Instance Number within the TERMINAL SLOT CLASS.
103 (67h)	Module ID	G	DWORD	Contains the module ID.
104 (68h)	Module order number	G	UDINT	Contains the ident number of the module.
105 (69h)	Module order name	G	SHORT STRING	Contains the name of the module, for example, "BL20-4DO-0.5A-P".
106 (6Ah)	Module revision	G	USINT	Contains the revision number of the module firmware.
107 (6Bh)	Module type ID	G	ENUM USINT	Describes the module type: see attribute 107 (6Bh) on page 5-34
108 (6Ch)	Module command interface	G/S	ARRAY	The control interface of the BL20 module. ARRAY OF: BYTE: Control byte sequence
109 (6Dh)	Module response interface	G	ARRAY	Response interface of the BL20 module. ARRAY OF: BYTE: Response byte sequence
110 (6Eh)	Module registered index	G	ENUM USINT	Contains the index numbers specified in all the module lists.

Table 5-53:
Object instance

Attr. No. dec. (hex.)	Attribute name	Get/ Set	Type	Description
111 (6Fh)	Module output channel count	G	USINT	Contains the number of input channels supported by the module.
112 (70h)	Module input channel count	G	USINT	Contains the number of output channels supported by the module.
Input data				
113 (71h)	Module input_1	G	DWORD	Input data of the module (according to channels).
114 (72h)	Module input_2	G	DWORD	Input data of the module (according to channels).
Output data				
115 (73h)	Module output_1	G	DWORD	Output data of the module (according to channels).
116 (74h)	Module output_2	G	DWORD	Output data of the module (according to channels).
Diagnosis data				
117 (75h)	Open circuit error_1	G	DWORD	This attribute contains diagnosis information about open circuit errors (according to channels).
118 (76h)	Open circuit error_2	G	DWORD	This attribute contains diagnosis information about open circuit errors (according to channels).
119 (77h)	Short circuit output error_1	G	DWORD	This attribute contains diagnosis information about output short-circuits (according to channels).
120 (78h)	Short circuit output error_2	G	DWORD	This attribute contains diagnosis information about output short-circuits (according to channels).
121 (79h)	Short circuit sensor error_1	G	DWORD	This attribute contains diagnosis information about sensor short-circuits (according to channels).
122 (7Ah)	Short circuit sensor error_2	G	DWORD	This attribute contains diagnosis information about sensor short-circuits (according to channels).
123 (7Bh)	Cable error_1	G	DWORD	This attribute contains diagnosis information about a wire break (channel 1 to 32).
124 (7Ch)	Cable error_2	G	DWORD	This attribute contains diagnosis information about a wire break (channel 33 to 64).

Table 5-53:
Object instance

Attr. No. dec. (hex.)	Attribute name	Get/ Set	Type	Description
Parameter data				
125 (7Dh)	Open circuit monitoring mode_2	G/S	DWORD	Enables the wire break detection mode (channel 1 to 32).
126 (7Eh)	Open circuit monitoring mode_1	G/S	DWORD	Enables the wire break detection (channel 33 to 64).
127 (7Fh)	Invert input data_1	G/S	DWORD	The input signal is inverted (channel 1 to 32).
128 (80h)	Invert input data_2	G/S	DWORD	The input signal is inverted (channel 33 to 64).
129 (81h)	Invert output data_1	G/S	DWORD	The output signal is inverted (channel 1 to 32).
130 (81h)	Invert output data_2	G/S	DWORD	The output signal is inverted (channel 33 to 64).
131 (82h)	reserved	-	-	-
132 (83h)	reserved	-	-	-
133 (84h)	Auto recovery output_1	G/S	DWORD	The outputs switch on automatically after an overload.
134 (85h)	Auto recovery output_1	G/S	DWORD	The outputs switch on automatically after an overload.
135 (86h)	reserved	-	-	-
136 (87h)	reserved	-	-	-
137 (88h)	Retriggered recovery output_1	G/S	DWORD	The outputs (channel 1 to 32) have to be retriggered in case of an overload.
138 (89h)	Retriggered recovery output_2	G/S	DWORD	The outputs (channel 33 to 64) have to be retriggered in case of an overload.
139 (8Ah)	Enable high side output driver_1	G/S	DWORD	Enables the high side output driver of channels (channel 1 to 32).
140 (8Bh)	Enable high side output driver_2	G/S	DWORD	Enables the high side output driver of channels (channel 33 to 64).
141 (8Ch)	Enable low side output driver_1	G/S	DWORD	Enables the low side output driver of channels (channel 1 to 32).

Table 5-53:
Object instance

Attr. No. dec. (hex.)	Attribute name	Get/ Set	Type	Description
142 (8Dh)	Enable low side output driver_2	G/S	DWORD	Enables the low side output driver of channels (channel 33 to 64).
143 (8Eh)	Filter 2500µs channel 1	G/S	DWORD	Enables the input filter of the channel (channel 1 to 32).
144 (8Fh)	Filter 2500µs channel 2	G/S	DWORD	Enables the input filter of the channel (channel 33 to 64).
145 (90h)	Fault value	G/S	DWORD	Activates the fault value for the channel (channel 1 to 32).
146 (91h)	Fault value	G/S	DWORD	Activates the fault value for the channel (channel 33 to 64).
147 (92h)	Block Diagnostics	G/S	DWORD	Channel specific diagnostic information is blocked (channel 1 to 32).
148 (93h)	Block Diagnostics	G/S	DWORD	Channel specific diagnostic information is blocked (channel 33 to 64).

5.3.19 Analog Versatile Module Class (VSC118)

This class contains all information and parameters for analog versatile modules.



Attention

In this class, chosen parameter options can only be deactivated by activating another option of this parameter.



Note

Please refer to paragraph "Class Instance of the VSC", [page 5-26](#), for the description of the class instances for VSC.

Object Instance

Table 5-54:
Object instance

Attr. No. dec. (hex.)	Attribute name	Get/ Set	Type	Description
100 (64h)	Max object attribute	G	USINT	Contains the number of the last object attribute to be implemented.
101 (65h)	Module present	G	BOOL	0 = module missing, base module without electronic module. 1 = module is plugged
102 (66h)	Terminal slot number	G	USINT	The slot number of the base module belonging to the module (base module to the right of the gateway = No. 1). Corresponds to the respective Instance Number within the TERMINAL SLOT CLASS.
103 (67h)	Module ID	G	DWORD	Contains the module ID.
104 (68h)	Module order number	G	UDINT	Contains the ident number of the module.
105 (69h)	Module order name	G	SHORT STRING	Contains the name of the module, for example, "BL20-4DO-0.5A-P".
106 (6Ah)	Module revision	G	USINT	Contains the revision number of the module firmware.
107 (6Bh)	Module type ID	G	ENUM USINT	Describes the module type: see attribute 107 (6Bh) on page 5-34
108 (6Ch)	Module command interface	G/S	ARRAY	The control interface of the BL20 module. ARRAY OF: BYTE: Control byte sequence
109 (6Dh)	Module response interface	G	ARRAY	Response interface of the BL20 module. ARRAY OF: BYTE: Response byte sequence
110 (6Eh)	Module registered index	G	ENUM USINT	Contains the index numbers specified in all the module lists.

Table 5-54:
Object instance

Attr. No.	Attribute name	Get/ Set	Type	Description
dec. (hex.)				
111 (6Fh)	Module input channel count	G	USINT	Contains the number of input channels supported by the module.
112 (70h)	Module output channel count	G	USINT	Contains the number of output channels supported by the module.
Input data				
113 (71h) to 128 (80h)	Module input 1 to Module input 16	G	UINT	Input data of the module (according to channels).
Output data				
129 (81h) to 144 (8Fh)	Module output_1 to Module output_16	G	DWORD	Output data of the module (according to channels).
Diagnosis data				
145 (90h)	Range error	G	WORD	Indicates an over- or undercurrent of 1 % of the set current/voltage range; whereby, undercurrents can only be recognized with those modules that have a set current range of 4 to 20 mA.
146 (91h)	Open circuit error	G	WORD	Indicates an open circuit in the signal line for the operating mode
147 (92h)	Short circuit error	G	WORD	
148 (93h)	reserved	-	-	-
Parameter data				
149 (94h) to 164 (A4h)	Channel 1 to Channel 16	G/S	UINT	Activates or deactivates the corresponding channel.
165 (A5h) to 180 (B4h)	Operating mode channel 1 to Operating mode channel 16	G/S	ENUM	Sets the operating mode for the channel 0 = deactivate channel 1 = -10 V...+10 V 2 = 0 V...+10 V 3 = 0 mA..20 mA 4 = 4 mA..20 mA

Implementation of EtherNet/IP

Table 5-54:
Object instance

Attr. No. dec. (hex.)	Attribute name	Get/ Set	Type	Description
181 (B5h) to 196 (C4h)	Value representation channel 1 to Value representation channel 16	G/S	ENUM	Sets the value representation for the channels: 0 = default 1 = 16 bit integer 2 = 12 bit left justified + diagnostics.

5.3.20 SWIRE module class (VSC121)

This class contains all the parameters and information for the BL20-E-SWIRE module.



Note

The SWIRE module class (VSC121) is only implemented in gateways with Maj. Rev. \geq 1.6.0.



Attention

In this class, chosen parameter options can only be deactivated by activating another option of this parameter.



Note

Please refer to paragraph "Class Instance of the VSC", [page 5-26](#), for the description of the class instances for VSC.

Object Instance

Table 5-55:
Object instance

Attr. No. dec. (hex.)	Attribute name	Get/ Set	Type	Description
100 (64h)	Max object attribute	G	USINT	Contains the number of the last object attribute to be implemented.
101 (65h)	Module present	G	BOOL	0 = module missing, base module without electronic module. 1 = module is plugged
102 (66h)	Terminal slot number	G	USINT	The slot number of the base module belonging to the module (base module to the right of the gateway = No. 1). Corresponds to the respective Instance Number within the TERMINAL SLOT CLASS.
103 (67h)	Module ID	G	DWORD	Contains the module ID.
104 (68h)	Module order number	G	UDINT	Contains the ident number of the module.
105 (69h)	Module order name	G	SHORT STRING	Contains the name of the module, for example, "BL20-E-1SWIRE".
106 (6Ah)	Module revision	G	USINT	Contains the revision number of the module firmware.
107 (6Bh)	Module type ID	G	ENUM USINT	Describes the module type: see attribute 107 (6Bh) on page 5-34
108 (6Ch)	Module command interface	G/S	ARRAY	The control interface of the module. ARRAY OF: BYTE: Control byte sequence

Table 5-55:
Object instance

Attr. No. dec. (hex.)	Attribute name	Get/ Set	Type	Description
109 (6Dh)	Module response interface	G	ARRAY	Response interface of the module. ARRAY OF: BYTE: Response byte sequence
110 (6Eh)	Module registered Index	G	ENUM USINT	Contains the index numbers specified in all the module lists.
111 (6Fh)	Number of supported input channels	G	USINT	Shows the number of input channels supported by this module instance.
112 (70h)	Number of supported output channels	G	USINT	Shows the number of output channels supported by this module instance.
SWIRE data				
113 (71h)	Input1_ DWORD	G	DWORD	Contains the first 4 bytes of the process input data.
114 (72h)	Input2_ DWORD	G	DWORD	Contains the last 4 bytes of the process input data
115 (73h)	Output1_ DWORD	G	DWORD	Contains the first 4 bytes of the process output data.
116 (74h)	Output2_ DWORD	G	DWORD	Contains the last 4 bytes of the process output data
117 (75h)	Diag common error	G	WORD	One bit per SWIRE slave shows if diagnostics messages are present or not Slave 1 belongs to bit 0, slave 2 to bit 1 etc. 0: o.k. 1: One/several diagnostics messages present
118 (76h)	Diag config error	G	WORD	One bit per SWIRE slave shows the configuration state of the slave: Slave 1 belongs to bit 0, slave 2 to bit 1 etc. 0: The bus is in data exchange mode 1: The configuration was not accepted, the bus does not switch to data exchange mode. (LED SW flashing)

Table 5-55:
Object instance

Attr. No. dec. (hex.)	Attribute name	Get/ Set	Type	Description
119 (77h)	Diag communication error	G	WORD	One bit per SWIRE slave shows possible communication errors. Slave 1 belongs to bit 0, slave 2 to bit 1 etc. 0: o.k. 1: A communication error is present, such as a slave is no longer reached, its internal timeout has elapsed or communication is faulty. The master cannot carry out data exchange with at least one slave.
120 (78h)	Diag PKZ error	G	WORD	One bit per SWIRE slave shows if the PKZ has tripped or not: Slave 1 belongs to bit 0, slave 2 to bit 1 etc. 0: No PKZ has tripped or diagnostics function has been deactivated via the parameter setting. 1: At least one PKZ has tripped.
121 (79h)	Param common operation modes	G/S	Byte	<p>Bit 0: reserved</p> <hr/> <p>Bit 1 = Automatic SWIRE configuration: 0: The physically present configuration of the SWIRE bus is only accepted as the ACTUAL configuration by pressing the CFG button. The comparison with the SET configuration is then carried out 1: The physically present configuration is automatically accepted as the ACTUAL configuration and then compared with the SET configuration.</p> <hr/> <p>Bit 2 = PLC configuration check 0: Configuration check based on device ID. Only SWIRE slaves with a device ID completely matching the set configuration are accepted on the bus 1: All slaves are mapped in 4Bit INPUT / 4Bit OUTPUT without checking the device ID.</p>

Table 5-55:
Object instance

Attr. No. dec. (hex.)	Attribute name	Get/ Set	Type	Description
121 (79h)	Param. common operation modes	G/S	Byte	<p>Bit 3 = Configuration check 0: No data exchange with a slave with an incomplete / incorrect configuration. 1: The bus also goes into operation with the correctly configured slaves even if the configuration is incomplete. This means in position oriented addressing: All slaves detected by the daisy chain configuration with a position that matches the set configuration are started up. Slaves that do not match the set configuration are inactive.</p> <p>Bit 4 to bit 6: reserved</p>
122 (7Ah)	Param. error report control	G/S	BYTE	<p>Bit 0 = Slave error field 0: Single diagnostics is activated 1: Single diagnostics is not activated</p> <p>Bit 1 = Group error - Slave error 0: Group diagnostics is activated 1: Group diagnostics is not activated</p> <p>Bit 2 = PKZ error field 0: Single diagnostics is activated 1: Single diagnostics is not activated</p> <p>Bit 3 = Group error - PKZ error 0: Group diagnostics is activated 1: Group diagnostics is not activated</p> <p>Bit 4 = Configuration error field 0: Single diagnostics is activated 1: Single diagnostics is not activated</p> <p>Bit 5 = Group error - Configuration error 0: Group diagnostics is activated 1: Group diagnostics is not activated</p> <p>Bit 6 = Error message - UAUX 0: Error message UAUXERR activated 1: Error message UAUXERR not activated</p> <p>Bit 7: reserved</p>
124 (7Ch)	Lifeguarding time	G/S	USINT	<p>02_{hex}-FF_{hex} Default: 64_{hex} Disconnect: FF_{hex} Setting of lifeguarding time, timeout time up to automatic reset of the slaves in the event of communication failure. (n × 10ms) (Default 1s)</p>

Table 5-55:
Object instance

Attr. No. dec. (hex.)	Attribute name	Get/ Set	Type	Description
125 (7Dh)	Process data slave diag	G/S	WORD	Input bit communication error, slave x 0: Slave diagnostics message from Byte 1 / Bit 7 is accepted in the feedback interface as Bit4 1: Slave diagnostics message from Byte 1 / Bit 7 is accepted in the feedback interface as Bit4
126 (7Eh), 127 (7Fh)	reserved			
128 (7Eh) - 143 (8Fh)	Param. SWIRE type ident slave 1 - Param. SWIRE type ident slave 16	G/S	BYTE	Bit 0 to bit 3 = Variant ID FF _{hex} = No slave 20 _{hex} = SWIRE-DIL-MTD

5.3.21 RFID-S module class (VSC124)

This class contains all information and parameters for the modules BL20-2RFID-S.



Attention

In this class, chosen parameter options can only be deactivated by activating another option of this parameter.



Note

Please refer to paragraph [section "Class Instance of the VSC"](#), [page 5-26](#), for the description of the class instances for VSC.

Object Instance



Note

The object instances of VSC 124 represent the individual RFID-S channels, not the complete modules!

Table 5-56:
Object instance

Attr. no. dec. (hex.)	Attribute name	Get/ Set	Type	Description
100 (64h)	Max object attribute	G	USINT	Contains the number of the last object attribute to be implemented.
101 (65h)	Module present	G	BOOL	0 = module missing, base module without electronic module. 1 = electronics module is plugged
102 (66h)	Terminal slot number	G	USINT	The slot number of the base module belonging to the module (base module to the right of the gateway = No. 1). Corresponds to the respective Instance Number within the TERMINAL SLOT CLASS.
103 (67h)	Module ID	G	DWORD	Contains the module ID.
104 (68h)	Module order number	G	UDINT	Contains the ident number of the module.
105 (69h)	Module order name	G	SHORT STRING	Contains the name of the module, for example, "BL20-2RFID-S".
106 (6Ah)	Module revision	G	USINT	Contains the revision number of the module firmware.
107 (6Bh)	Module type ID	G	ENUM USINT	Describes the module type: see attribute 107 (6Bh) on page 5-34
108 (6Ch)	Module command interface	G/S	ARRAY	The control interface of the module. ARRAY OF: BYTE: Control byte sequence

Table 5-56:
Object instance

Attr. no. dec. (hex.)	Attribute name	Get/ Set	Type	Description
109 (6Dh)	Module response interface	G	ARRAY	Response interface of the module. ARRAY OF: BYTE: Response byte sequence
110 (6Eh)	Diag size	G	UINT	Indicates the number of diagnostic bits of the module.
111 (6Fh)	Diag	G	WORD	Contains the diagnostic information of the module. WORD: Bit for bit assignment according to module specification.
112 (70h)	Module registered index	G	ENUM USINT	Contains the index numbers specified in all the module lists.
113 (71h)	Module output data	G	ARRAY OF BYTE	Process data output information.
114 (72h)	Module input data	G	ARRAY OF BYTE	Process data input information.
115 (73h)	Bypass time channel 1	G/S	WORD	Bypass time in ms
116 (74h)	Bypass time channel 2	G/S	WORD	Bypass time in ms



Note

For further information concerning the RFID communication interfaces see the special RFID documentation which can be downloaded from www.turck.com.

6 Application example: BL20 gateway with an Allen Bradley PLC

6.1	General.....	2
6.1.1	Prerequisites for this example	2
	– Example station	2
6.2	Network configuration	3
6.3	Changing the IP address of a PC/ network interface card	4
6.3.1	Changing the IP address in Windows 2000/ Windows XP	4
6.3.2	Changing the IP address in Windows NT.....	5
6.3.3	Changing the IP address via I/O-ASSISTANT V3	6
	– Deactivating/ adapting the firewall in Windows XP	8
6.4	Address setting at the gateway	10
6.4.1	Address setting via DHCP-mode	10
6.5	Setting-up communications with the software tool "RSLinx"	13
6.6	Configuration of the network in "RSLogiX 5000"	14
6.6.1	Configuration of the controller	14
6.6.2	Configuration of a BL20 station	16
6.6.3	Downloading the I/O configuration	18
6.7	Examples for I/O data mapping	20
6.7.1	Mapping report via I/O-ASSISTANT	22
6.8	Example for process data access	23
6.8.1	Setting outputs at BL20-2DO-0.5A-P	23

6.1 General

The following example shows detailed information about the connection of a BL20 station for EtherNet/IP to an Allen Bradley PLC.

6.1.1 Prerequisites for this example

In order to configure BL20 devices and to build up communications with the Allen Bradley ControlLogix PLC over EtherNet/IP, the following software tools and hardware devices are necessary.

Software:

- RSLinX - used to establish communication over EtherNet/IP
- RSLogix 5000 - used to configure the controller and the other network hosts

Hardware used in this example:

- Allen Bradley PLC 1756-L55/ A 1756-M12/A LOGIX5555,
- Ethernet Bridge 1756-ENBT/A
- BL20 station with a gateway BL20-GW-EN-IP with EtherNet/IP protocol

Example station

The following station is used in this application example:

Table 6-1:
Example station

Module		Data width		
		Process in	Process out	Alignment
GW	BL20-GW-EN-IP			
0	BL20-2AI-I(0/4...20MA)	2 words	-	word by word
1	BL20-2DI-24VDC-P	2 bits	-	bit by bit
2	BL20-2DO-24VDC-0.5A-P	-	2 bits	bit by bit
3	BL20-2AI-THERMO-PI	2 words	-	word by word
4	BL20-4DI-24VDC-P	4 bits		bit by bit
5	empty slot			
6	BL20-1AI-U(-10/0...+10VDC)	1 word	-	word by word
7	BL20-2AO-I(0/4...20MA)		2 words	word by word
8	BL20-4DI-24VDC-P	4 bits		bit by bit
9	BL20-1SSI	4 words	4 words	word by word

6.2 Network configuration

The BL20 gateways are delivered with the IP address **192.168.1.1**.



Note

In order to build up the communication between the BL20 gateway and a PLC/ PC or a network interface card, both devices have to be hosts in the same network.

To achieve this, you have whether

- to adjust the gateway's IP address via BootP, DHCP etc. for integrating it into your own network (for detailed information about the different possibilities for address setting, please read, [chapter 4, Address setting \(page 4-8\)](#)).

or

- to change the IP address of the used PC or network interface card (for detailed information, please read the following [section "Changing the IP address of a PC/ network interface card"](#), page 6-4).

6.3 Changing the IP address of a PC/ network interface card

6.3.1 Changing the IP address in Windows 2000/ Windows XP

The IP address is changed in the "Control Panel" in "Network and Dial-up Connections":

- 1 Open the folder "Local Area Connection" and open the dialog "Local Area Connection Properties" via the button "Properties" in the dialog "Local Area Connection Status".
- 2 Mark "Internet Protocol (TCP/IP)" and press the "Properties"-button to open the dialog "Internet Protocol (TCP/IP) Properties".

Figure 6-1:
Local Area
Connection
Properties

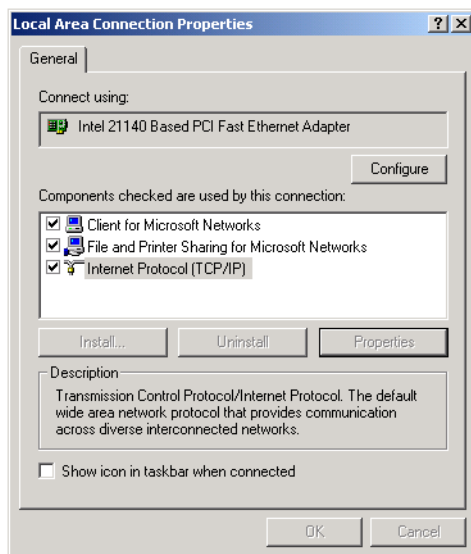

- 3 Activate "Use the following IP address" and assign an IP address of the network mentioned above to the PC/ Network interface card (see the following figure).

Figure 6-2:
Changing the
PC's IP address

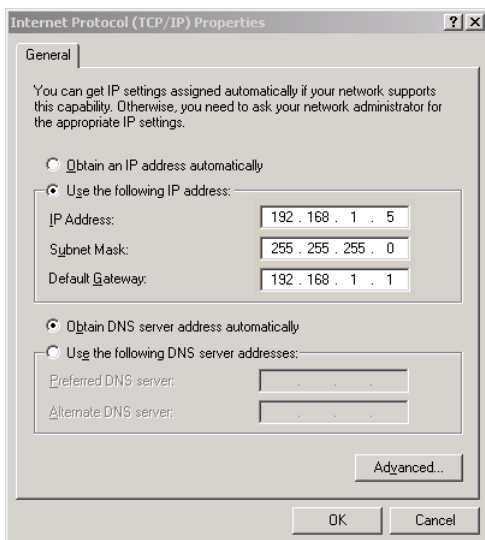

6.3.2 Changing the IP address in Windows NT

- 1 Open the folder "Network" in the Control Panel.
- 2 Activate TCP/IP connection in the tab "Protocols" and click the "Properties" button.

Figure 6-3:
Network configuration WIN NT

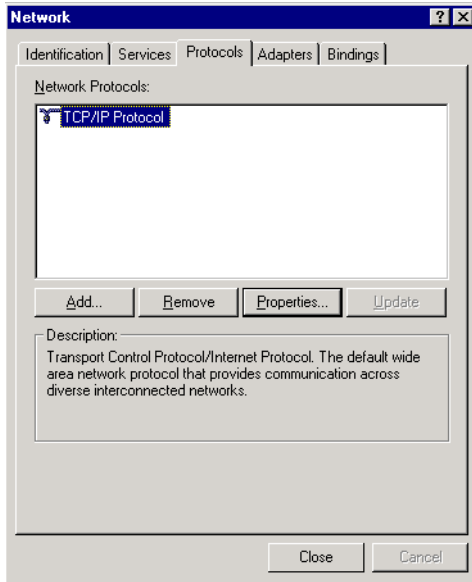

- 3 Activate "Specify IP address " and set the address as follows.

Figure 6-4:
Specify IP address

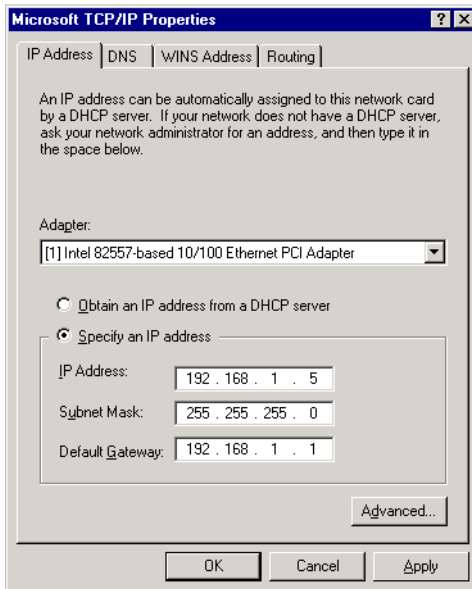

6.3.3 Changing the IP address via I/O-ASSISTANT V3

The Busaddress Management DTM in the software I/O-ASSISTANT offers the possibility to browse the whole Ethernet network for connected nodes and to change their IP address as well as the subnet mask according to the application.

Select the used network card under "Online available devices" and browse the connected network by pressing the search button.

Figure 6-5:
Busaddress
Management in
the
I/O-ASSISTANT

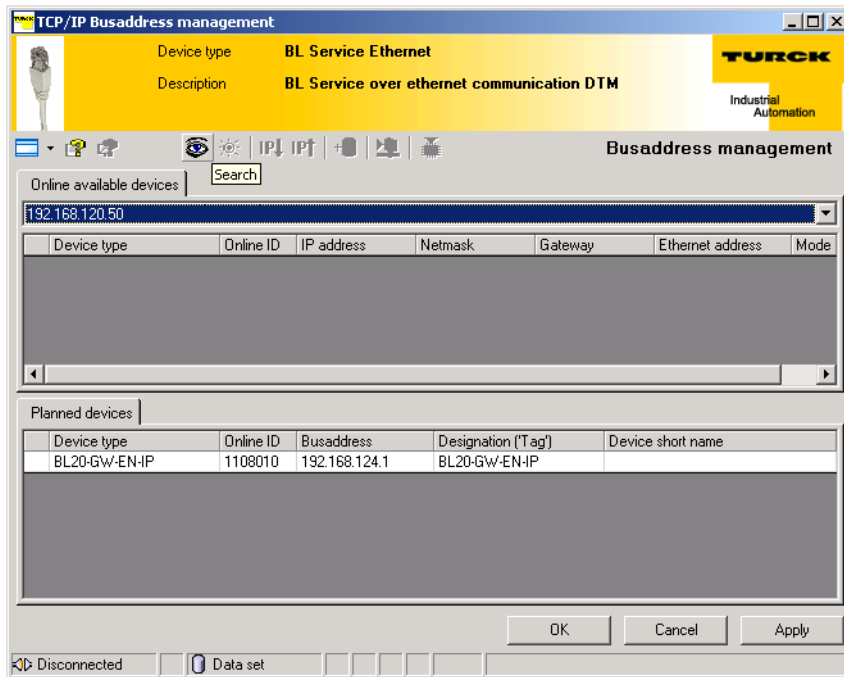

Attention

If Windows XP is used as operating system, problems with the system internal firewall may occur.

It may eventually inhibit the access of the I/O-ASSISTANT to the Ethernet. Please adapt your firewall settings accordingly or deactivate it completely (see also [Deactivating/ adapting the firewall in Windows XP, page 6-8](#)).

The network is browsed for connected nodes which are then listed in the Busaddress Management. It is now possible to change the address settings for all nodes in the list or only for the selected one. Mark the selected node, enter a new IP address and apply this address by confirming the changes using the "Apply" button.

Figure 6-6:
Address changing for selected nodes

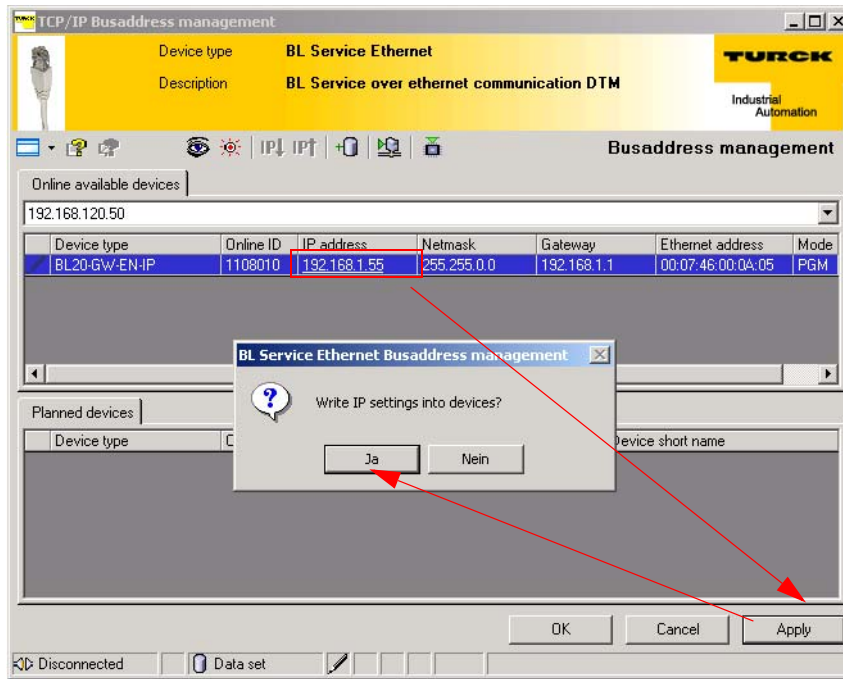

Note

For further information about the I/O-ASSISTANT, it's functions and it's handling, please read the online help of the software.

Deactivating/ adapting the firewall in Windows XP

If you use Windows XP as operating system, problems may occur when changing the IP addresses via the I/O-ASSISTANT.

In this case, you can deactivate the system integrated Windows XP firewall completely or adapt it to your application.

■ **Deactivating the firewall**

Open the "Windows Firewall" dialog in the control panel of your PC and deactivate it as follows:

*Figure 6-7:
Deactivating
the Windows
firewall*

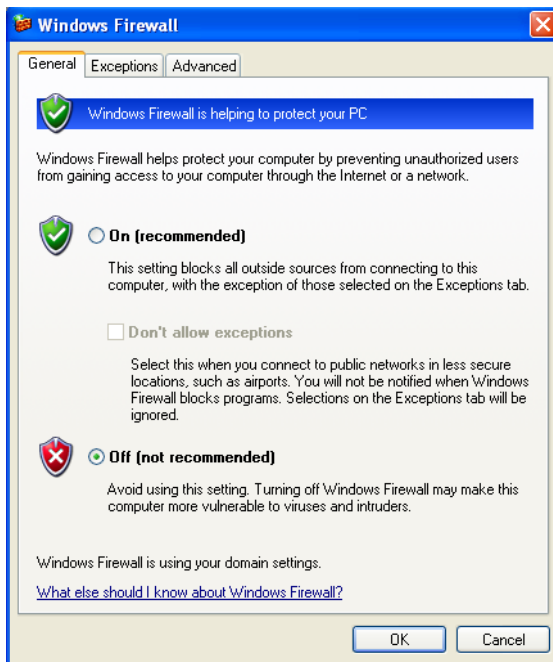

■ **Adapting the firewall**

The firewall remains active, the option "Don't allow exceptions" it deactivated:

*Figure 6-8:
Activating the
Windows fire-
wall*

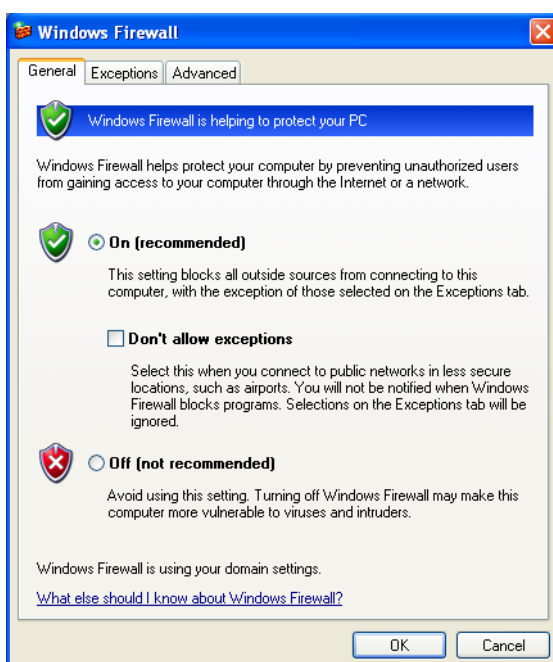

- In the "Exceptions"-tab, add the I/O-ASSISTANT to "Programs and Services".
- Pressing the button "Add Program..." opens the dialog "Add a Program". Select the I/O-ASSISTANT from the list of installed programs.
- If necessary, use the button "Browse..." to choose the file "IOassistant.exe" from the installation directory of the software.

Figure 6-9:
"Exceptions"-
tab

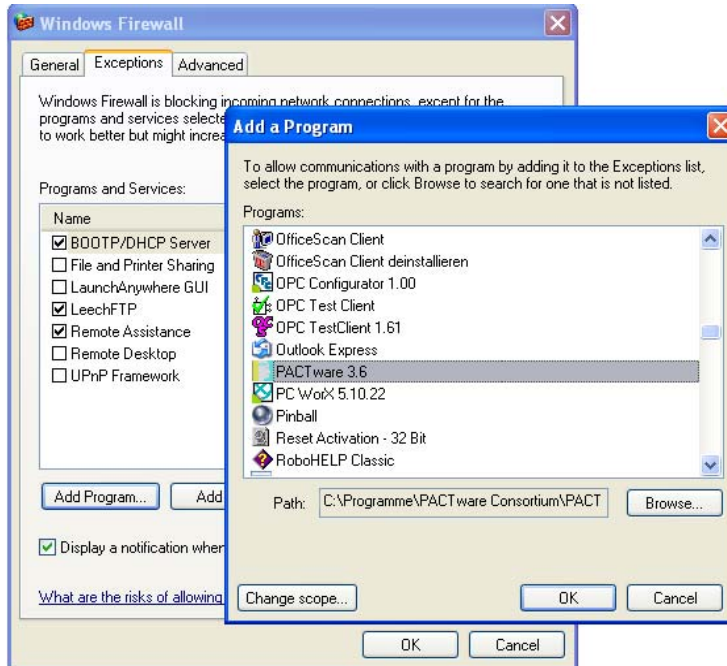

- Despite an active firewall, the I/O-ASSISTANT is now able to browse the network for hosts and the address changing via the software is possible for the connected nodes.

6.4 Address setting at the gateway

6.4.1 Address setting via DHCP-mode

In this application example, the IP address is set via DHCP using the software tool "BootP/DHCP-Server" version 2.3.2.0 from Rockwell Automation.

Figure 6-10:
BootP-Server
from Rockwell
Automation

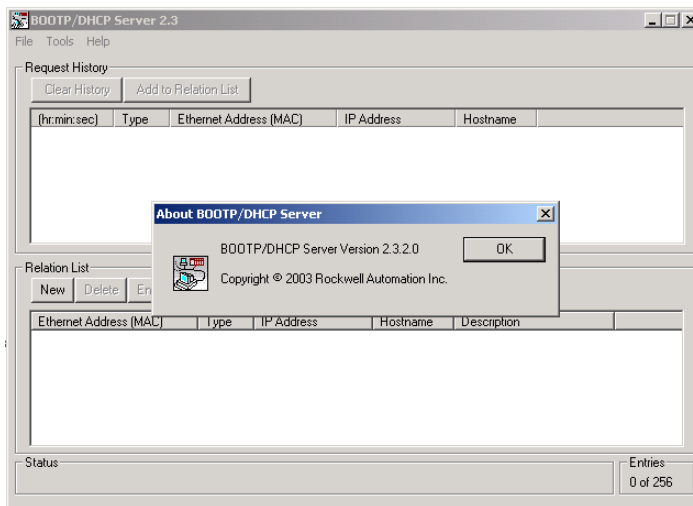

Addresses in the range from 1 to 254 can be allocated. The addresses 0 and 255 are reserved for broadcast messages in the subnet.



Note

The rotary coding switches on the gateway must be set to "400" in order to enable the DHCP-Mode.

After having been connected to the network, the BL20 sends DHCP requests to the server using its MAC-ID.

Figure 6-11:
DHCP-request
of BL20 gateway

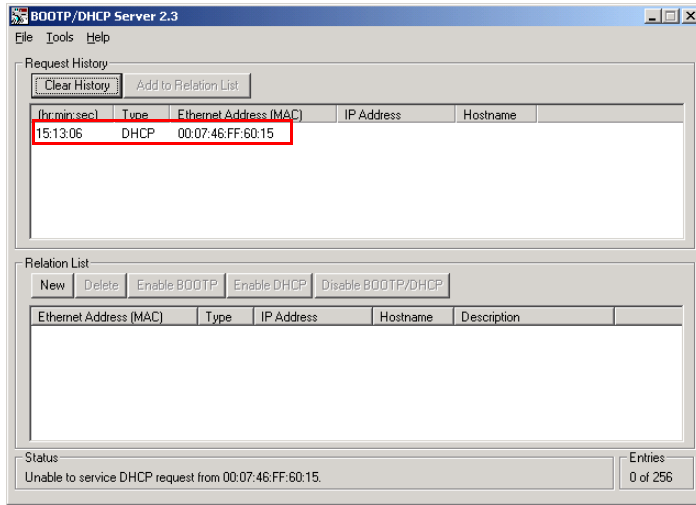

A double click on the request-entry opens the "New Entry" dialog box in which an IP address can be assigned to the module's MAC-ID.

Figure 6-12:
Setting the IP
address via
DHCP

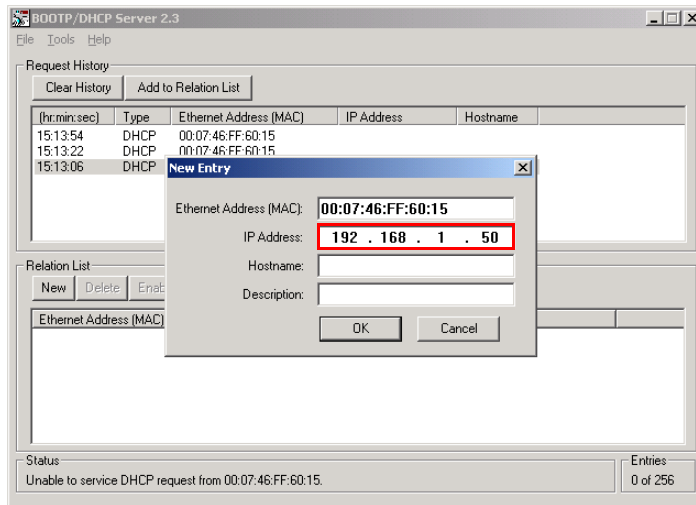

Application example: BL20 gateway with an Allen Bradley PLC

The BootP/DHCP-Server sends the IP Address via BootP/DHCP to the BL20 gateway and, after a few seconds, the gateway answers with its new IP address when having stored it.

Figure 6-13:
Setting the IP
address via
DHCP

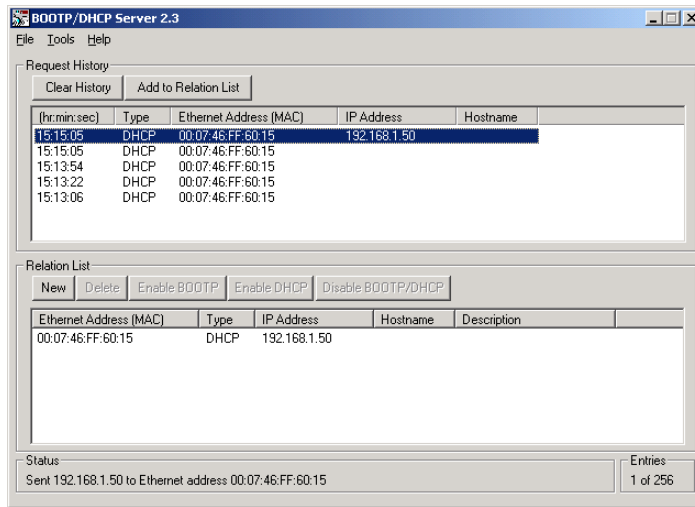

The "Relation list" can be stored for further applications. It can serve for permanent assignment of defined IP addresses to MAC-IDs/ modules.



Attention

If the BootP/DHCP-server is shut down, the BL20 gateway loses the IP address after a power reset!

6.5 Setting-up communications with the software tool "RSLinx"

Before the EtherNet/IP network can be configured, access to EtherNet/IP must be established using the software "RSLinx" (version 2.43.01) from Rockwell Automation.

The following example explains the creation of a connection via the Allen Bradley EtherNet/IP interface.

The selection of the EtherNet/IP Driver module is done using the "Communications → Configure Drivers" command.

Select the driver type category "EtherNet/IP Driver".

Once the driver type has been selected, click the "Add new" button and choose a name for the new EtherNet/IP Driver.

Figure 6-14:
Selecting the
EtherNet/IP
Driver module

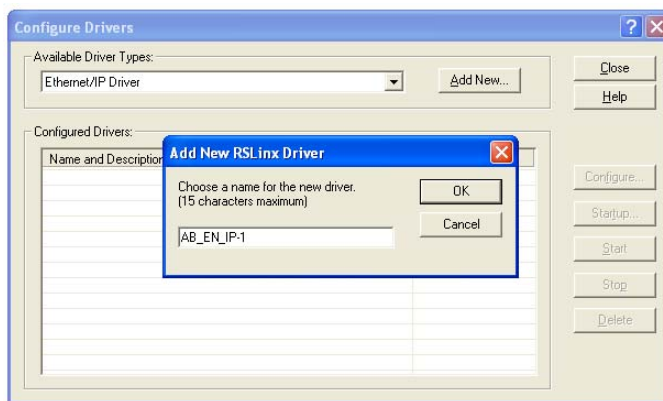

The connection to EtherNet/IP is established following successful configuration driver.

In RSLinx, the "Autobrowse" function can be used to scan the network. All hosts in the network, which is defined by the settings of your network card, will be found.

Figure 6-15:
Scanning the
EtherNet/IP
network via
RSWho

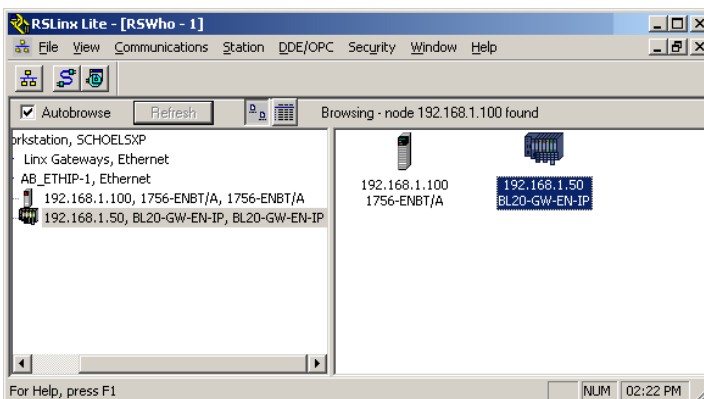

6.6 Configuration of the network in "RSLogix 5000"

The EtherNet/IP hosts (PLC, EtherNet/IP interface, I/O modules) have to be configured using the software "RSLogix 5000" (in this example version 15) from Rockwell Automation.

Start RSLogix and open a new project using the "File" menu.

Figure 6-16:
Creating a new
project in
RSLogix

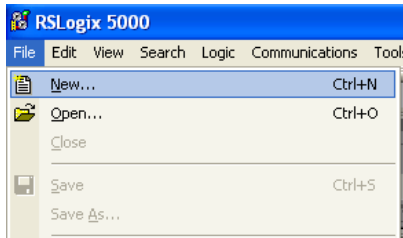

6.6.1 Configuration of the controller

Enter the information related to the controller depending on your configuration, as well as a name for the project.

Figure 6-17:
Configuration
of the controller

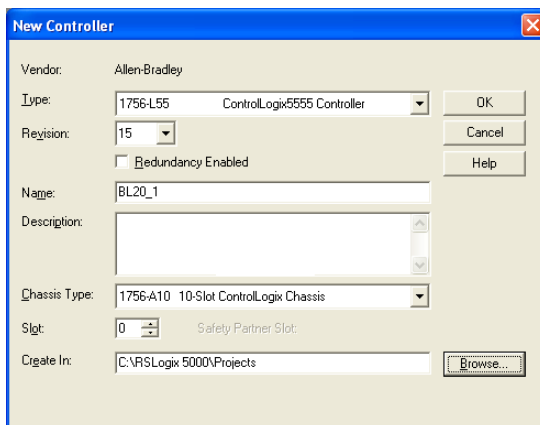

Your project will be opened offline. In order to configure the network, please right-click "I/O Configuration" and select "new Module" to add the first host, the EtherNet/IP bridge, to the network. Open "Communications" and select the bridge. In this example this would be 1756-ENBT/A.

Figure 6-18: Selection of the EtherNet/IP bridge

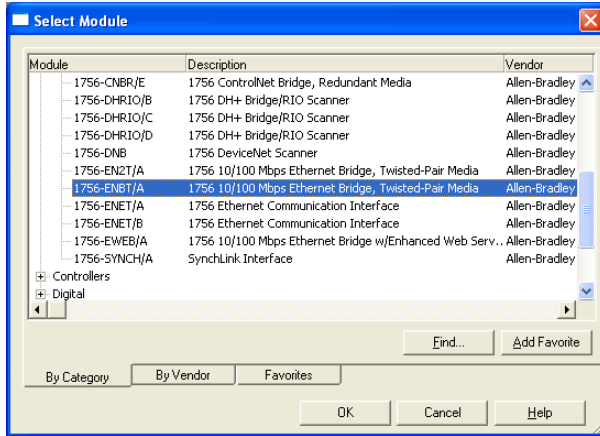

Enter the "Major Revision" of your EtherNet/IP bridge and click "OK".

Figure 6-19: Major Revision of the EtherNet/IP Bridge

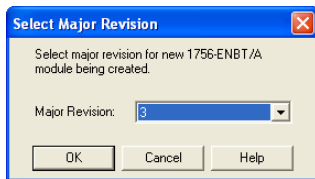

In the following dialog box "New Module" enter a name for the bridge and define its IP Address (in this example 192.168.1.100).

Figure 6-20: Configuring the EtherNet/IP Bridge

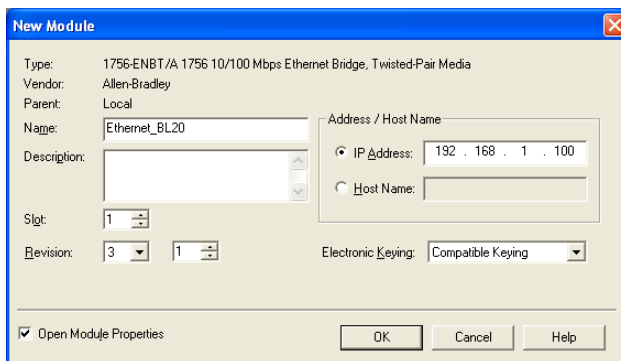

In the following dialog box "Module Properties: Local..." press "OK". You may also browse offline through the module properties when you click "Next". At this point there is no need for further entry action. If "Next" is selected, the "Module Properties" window displays information that will be available when the module is online. The configuration of the interface is completed. Press "Finish" to close the dialog box.

6.6.2 Configuration of a BL20 station

Add the BL20 to the I/O configuration by using a right-click on the EtherNet/IP bridge module 1756-ENBT/A and select "New Module".

Figure 6-21:
Adding the BL20 station to the I/O configuration

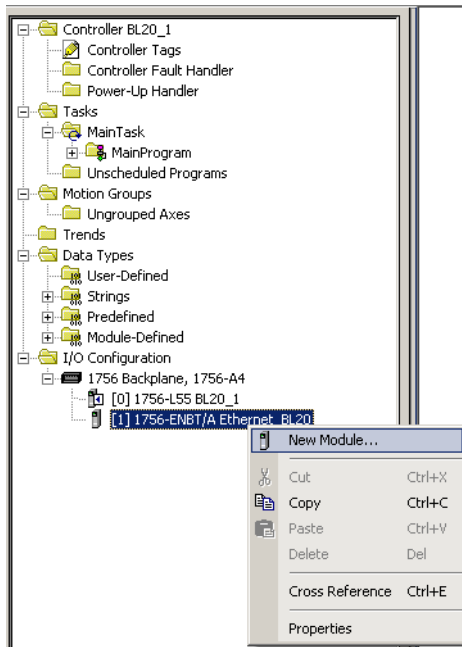

Open "Communications" and select the entry "Generic Ethernet Module" to configure a BL20 gateway.

Figure 6-22:
Add generic Ethernet module

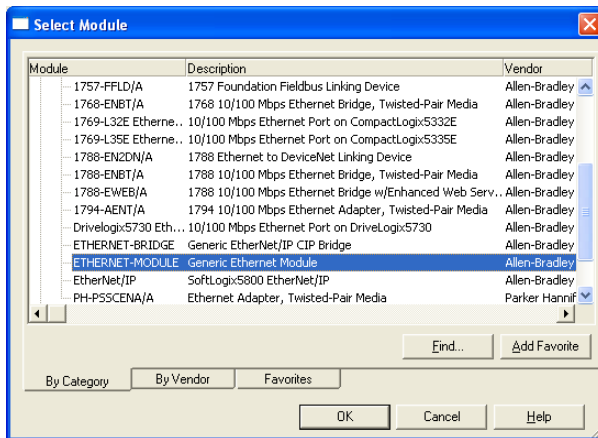

Enter the necessary device information, like "Module name" and "Communication format" and define the gateway's IP Address and the connection parameters.

For the Assembly Instances 101 and 102, the Connection Parameters (input and output size = 256 Byte each) are static and have to be set as follows:

Figure 6-23: Configuration of BL20 gateway

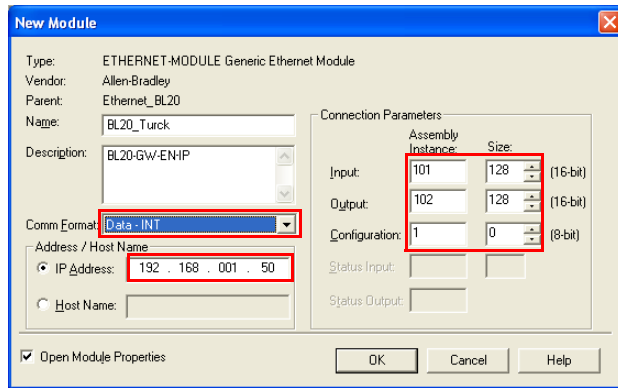

Note

If the variable Assembly Instances 103 and 104 (see [Instance 103 + Instance 104 \(page 5-14\)](#)) are used, the Connection Parameters have to be set according to the actual station configuration which means, the in- and output sizes have to match the sizes definitely required by the station. This required in- and output size (2 to max. 496 Byte) can be read out using Assembly Class (0x04), Instance 0x67, Attr. 0x04 and Assembly Class (0x04), Instance 0x68, Attr. 0x04.

In the "Connection" tab set the "Requested Packet Interval" (RPI) to 10 ms, which normally should be the default setting. For BL20, the successfully tested RPI range is 5 and higher.

Figure 6-24: Set connection options for BL20

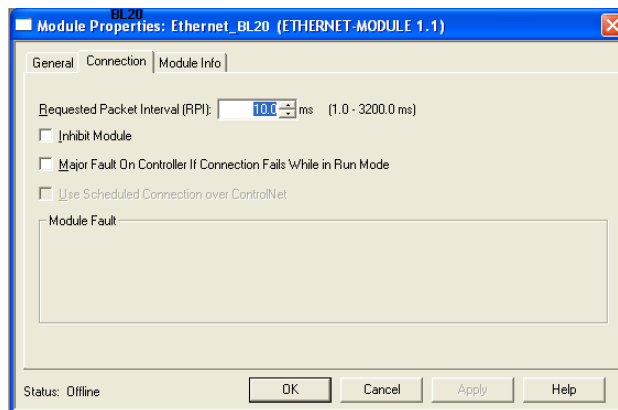

6.6.3 Downloading the I/O configuration

If the configuration of the network is completed, it can be downloaded to the controller by using for example the "Communication → Download" command.

Figure 6-25:
Downloading
the configura-
tion

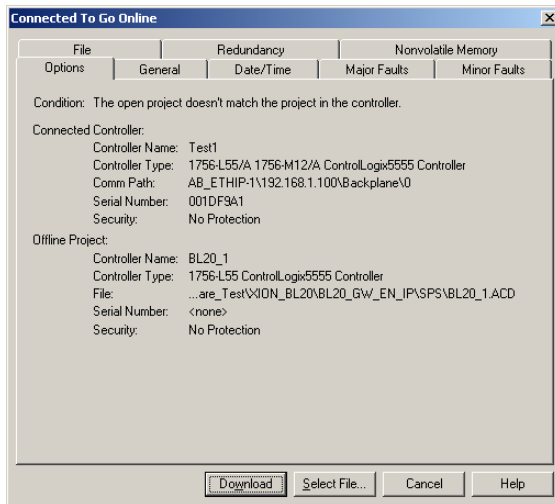

In the "Download" dialog box, start the download by pressing the "Download" button.

Figure 6-26:
Downloading
the configura-
tion

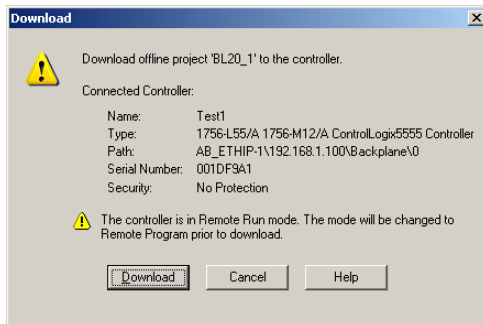

If an error message is generated, warning, that the communication path can not be found, please open the "Path" menu (see Figure 6-28);, select your controller and press "Set Project Path" (see Figure 6-29;).

Figure 6-27: Error message

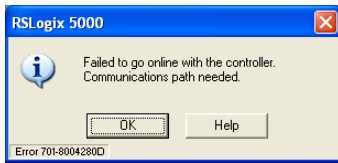

Figure 6-28: Communication Path

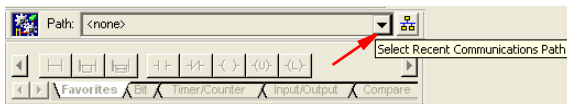
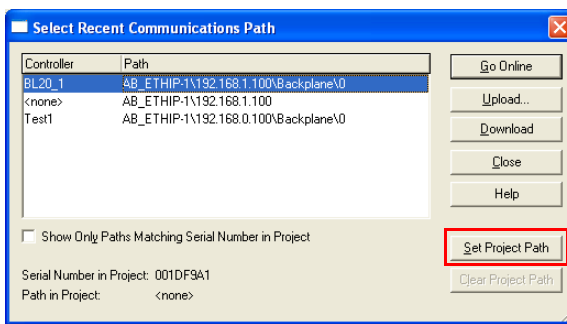

Figure 6-29: Communication Path



If the correct communication path is set, it is possible to download the configuration.

Once the I/O configuration is downloaded and the controller is in "Run" or "Remote Run" mode, the I/O-data mapping of the BL20 station is shown in the "Controller Tags":

Figure 6-30: Controller Tags

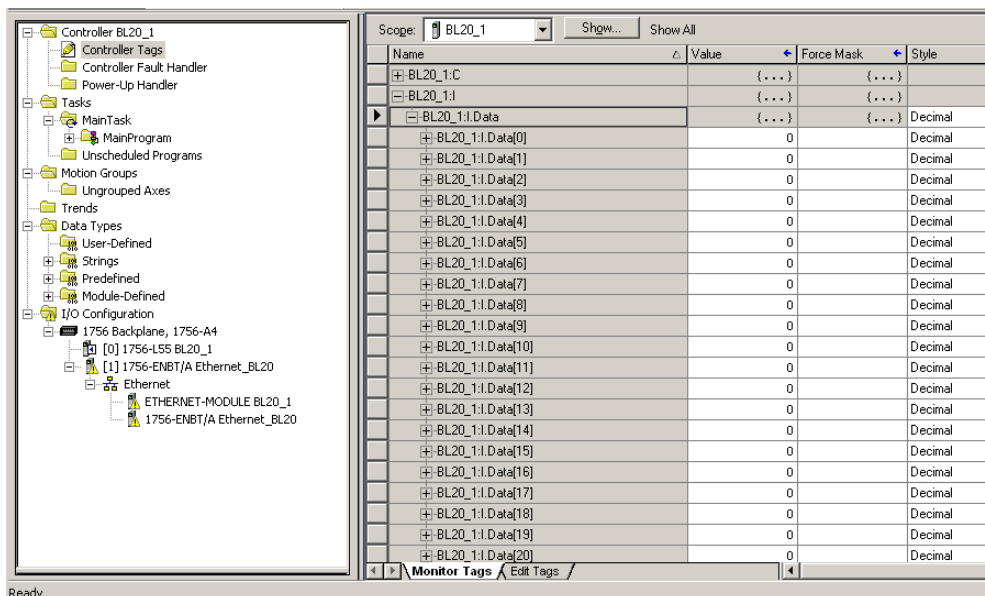

The controller tags for BL20 are divided into:

- BL20_Turck: C - the station's mapped configuration data
- BL20_Turck: I - the station's mapped input data
- BL20_Turck: O - the station's mapped output data

6.7 Examples for I/O data mapping

Each module is now accessible via the controller tags for viewing input data and/or forcing outputs. The data mapping depends on the data width of each module connected to the gateway.

*Table 6-2:
Example station*

Module		Data width	
		Process input	Process output
GW	BL20-GW-EN-IP	1 status word	1 control word
0	BL20-2AI-I(0/4...20MA)	2 words	-
1	BL20-2DI-24VDC-P	2 bits	-
2	BL20-2DO-24VDC-0.5A-P	-	2 bits
3	BL20-2AI-THERMO-PI	2 words	-
4	BL20-4DI-24VDC-P	4 bits	-
5	empty slot	-	-
6	BL20-1AI-U(-10/0...+10VDC)	1 word	-
7	BL20-2AO-I(0/4...20MA)	-	2 words
8	BL20-4DI-24VDC-P	4 bits	-
9	BL20-1SSI	4 words	4 words

According to the I/O data widths of the modules in the example station (see [Table 6-2: Example station](#)), the I/O data mapping for the example station is the following:

<i>Table 6-3: Data mapping for the example station</i>	Module		I/O data word in RSLogix
<i>AI.Data[0] = Byte 0 of mapped input data</i>	GW	BL20-GW-EN-IP	– Input data: A BL20: I.Data [0] ; Status Word
	0	BL20-2AI-I(0/4...20MA)	– Output data: BL20: O.Data [0] ; Command Word
	1	BL20-2DI-24VDC-P	– Input data: BL20: I.Data [1] ; ch. 0 BL20: I.Data [2] ; ch. 1
	2	BL20-2DO-24VDC-0.5A-P	– Input data: BL20: I.Data [3] ; Bits 0 and 1 for ch. 0 and 1.
	3	BL20-2AI-THERMO-PI	– Output data: BL20: O.Data [1] ; Bits 0 and 1 for ch. 0 and 1.
	4	BL20-4DI-24VDC-P	– Input data: BL20: I.Data [4] ; ch. 0: BL20: I.Data [5] ; ch. 1:
	5	empty slot	-
	6	BL20-1AI-U(-10/0...+10VDC)	– Input data BL20: I.Data [6] ; Bits 2 to 5 for ch. 0 to 3.
	7	BL20-2AO-I(0/4...20MA)	– Output data: BL20: I.Data [7] ; ch. 0
	8	BL20-4DI-24VDC-P	– Output data: BL20: O.Data [2] ; ch. 0 BL20: O.Data [3] ; ch. 1
9	BL20-4DI-24VDC-P	– Input data BL20: I.Data [8] ; Bits 0 to 3 for ch. 0 to 3.	
	BL20-1SSI	– Input data BL20: I.Data [9 - 12] – Output data BL20: O.Data [4 - 7]	

6.7.1 Mapping report via I/O-ASSISTANT

An EtherNet/IP I/O mapping report can be generated for each individual station by means of the software tool I/O-ASSISTANT.

Figure 6-31:
I/O mapping report in software tool I/O-ASSISTANT

1. Station (Adr.: 192.168.1.1) description and I/O sizes in/out

Module Pos.	Module Part Number	Desc.	Data Size In	Data Size Out
Position 0*	BL20-GW-EN-IP	Term OA	16 bits(status)	16 bits(control)
Position 1	BL20-2AI-(0/4...20MA)	Term OB	32 bits	0 bits
Position 2	BL20-2DI-24VDC-P	Term OC	2 bits	0 bits
Position 3	BL20-2DO-24VDC-0.5A-P	Term OD	0 bits	2 bits
Position 4	BL20-2AI-THERMO-PI	Term OE	32 bits	0 bits
Position 5	BL20-4DI-24VDC-P	Term OF	4 bits	0 bits
Position 6	Empty Place	Term OG	0 bits	0 bits
Position 7	BL20-1AI-U(-10/0...+10VDC)	Term OH	16 bits	0 bits
Position 8	BL20-2AO-(0/4...20MA)	Term OI	0 bits	32 bits
Position 9	BL20-4DI-24VDC-P	Term OJ	4 bits	0 bits
Position 10	BL20-1SSI	Term OK	64 bits	64 bits
Total Data In/Out size in Bytes (rounded on full words):			26 Byte	16 Byte

*For detailed information on Status/Control word see online Help - choose your gateway, click right for technical data

2. I/O map allocates 26 bytes for input data

Bit	Byte n+1								Byte n							
	15	14	13	12	11	10	9	8	7	6	5	4	3	2	1	0
Word 0*	0A.15	0A.14	0A.13	0A.12	0A.11	0A.10	0A.9	0A.8	0A.7	0A.6	0A.5	0A.4	0A.3	0A.2	0A.1	0A.0
Word 1	0B.15	0B.14	0B.13	0B.12	0B.11	0B.10	0B.9	0B.8	0B.7	0B.6	0B.5	0B.4	0B.3	0B.2	0B.1	0B.0
Word 2	0C.15	0C.14	0C.13	0C.12	0C.11	0C.10	0C.9	0C.8	0C.7	0C.6	0C.5	0C.4	0C.3	0C.2	0C.1	0C.0
Word 3	-	-	-	-	-	-	-	-	-	-	-	-	-	-	0C.1	0C.0
Word 4	0E.15	0E.14	0E.13	0E.12	0E.11	0E.10	0E.9	0E.8	0E.7	0E.6	0E.5	0E.4	0E.3	0E.2	0E.1	0E.0
Word 5	0F.15	0F.14	0F.13	0F.12	0F.11	0F.10	0F.9	0F.8	0F.7	0F.6	0F.5	0F.4	0F.3	0F.2	0F.1	0F.0
Word 6	-	-	-	-	-	-	-	-	-	-	-	-	0F.3	0F.2	0F.1	0F.0
Word 7	0H.15	0H.14	0H.13	0H.12	0H.11	0H.10	0H.9	0H.8	0H.7	0H.6	0H.5	0H.4	0H.3	0H.2	0H.1	0H.0
Word 8	-	-	-	-	-	-	-	-	-	-	-	-	0J.3	0J.2	0J.1	0J.0
Word 9	0K.15	0K.14	0K.13	0K.12	0K.11	0K.10	0K.9	0K.8	0K.7	0K.6	0K.5	0K.4	0K.3	0K.2	0K.1	0K.0
Word 10	0K.31	0K.30	0K.29	0K.28	0K.27	0K.26	0K.25	0K.24	0K.23	0K.22	0K.21	0K.20	0K.19	0K.18	0K.17	0K.16
Word 11	0K.47	0K.46	0K.45	0K.44	0K.43	0K.42	0K.41	0K.40	0K.39	0K.38	0K.37	0K.36	0K.35	0K.34	0K.33	0K.32
Word 12	0K.63	0K.62	0K.61	0K.60	0K.59	0K.58	0K.57	0K.56	0K.55	0K.54	0K.53	0K.52	0K.51	0K.50	0K.49	0K.48

*For detailed information on Status word see online Help - choose your gateway, click right for technical data

3. I/O map allocates 16 bytes for output data

Bit	Byte n+1								Byte n							
	15	14	13	12	11	10	9	8	7	6	5	4	3	2	1	0
Word 0*	0A.15	0A.14	0A.13	0A.12	0A.11	0A.10	0A.9	0A.8	0A.7	0A.6	0A.5	0A.4	0A.3	0A.2	0A.1	0A.0
Word 1	-	-	-	-	-	-	-	-	-	-	-	-	-	-	0D.1	0D.0
Word 2	0I.15	0I.14	0I.13	0I.12	0I.11	0I.10	0I.9	0I.8	0I.7	0I.6	0I.5	0I.4	0I.3	0I.2	0I.1	0I.0
Word 3	0I.31	0I.30	0I.29	0I.28	0I.27	0I.26	0I.25	0I.24	0I.23	0I.22	0I.21	0I.20	0I.19	0I.18	0I.17	0I.16
Word 4	0K.15	0K.14	0K.13	0K.12	0K.11	0K.10	0K.9	0K.8	0K.7	0K.6	0K.5	0K.4	0K.3	0K.2	0K.1	0K.0
Word 5	0K.31	0K.30	0K.29	0K.28	0K.27	0K.26	0K.25	0K.24	0K.23	0K.22	0K.21	0K.20	0K.19	0K.18	0K.17	0K.16
Word 6	0K.47	0K.46	0K.45	0K.44	0K.43	0K.42	0K.41	0K.40	0K.39	0K.38	0K.37	0K.36	0K.35	0K.34	0K.33	0K.32
Word 7	0K.63	0K.62	0K.61	0K.60	0K.59	0K.58	0K.57	0K.56	0K.55	0K.54	0K.53	0K.52	0K.51	0K.50	0K.49	0K.48

*For detailed information on Control word see online Help - choose your gateway, click right for technical data

6.8 Example for process data access

6.8.1 Setting outputs at BL20-2DO-0.5A-P

Example:

To set the outputs "0" and "1" at module no. 2 in the example station (BL20-2DO-24VDC-0.5A-P), bit 0 bit 1 in output data word 1 (BL20:O.Data [1]) have to be set (see above [Table 6-3: Data mapping for the example station](#)).

Figure 6-32:
Setting outputs
at module no. 7

Name	Value	Force	Mask	Style
BL20_1:C	{...}		{...}	
BL20_1:I	{...}		{...}	
BL20_1:O	{...}		{...}	
BL20_1:O.Data	{...}		{...}	Decimal
BL20_1:O.Data[0]	0			Decimal
BL20_1:O.Data[1]	3			Decimal
BL20_1:O.Data[2]			7 6 5 4 3 2 1 0	Decimal
BL20_1:O.Data[3]	7-0	0	0 0 0 0 0 0 1 1	Decimal
BL20_1:O.Data[4]	15-8	0	0 0 0 0 0 0 0 0	Decimal
BL20_1:O.Data[5]	0			Decimal
BL20_1:O.Data[6]	0			Decimal
BL20_1:O.Data[7]	0			Decimal
BL20_1:O.Data[8]	0			Decimal
BL20_1:O.Data[9]	0			Decimal
BL20_1:O.Data[10]	0			Decimal
BL20_1:O.Data[11]	0			Decimal
BL20_1:O.Data[12]	0			Decimal

Application example: BL20 gateway with an Allen Bradley PLC

7 Guidelines for station planning

7.1	Random module arrangement.....	2
7.1.1	Complete planning.....	2
7.1.2	Maximum system extension	2
7.2	Power supply	4
7.2.1	Module bus refreshing	4
7.2.2	Creating potential groups.....	7
7.2.3	Protecting the service interface on the gateway.....	8
7.2.4	C-Rail (cross connection)	8
7.2.5	Direct wiring of relay modules	10
7.3	Plugging and pulling electronics modules	11
7.4	Extending an existing station	12
7.5	Firmware download	13

7.1 Random module arrangement

The arrangement of the I/O-modules within a BL20 station can basically be chosen at will. Nevertheless, it can be useful with some applications to group certain modules together.



Note

The mixed usage of base modules with screw connections and base modules with tension clamp connections requires a further power supply module to be mounted. Thereby, it must be ensured that the base modules are fitted with the same connection technology (screw or tension clamp) as the power supply module.

7.1.1 Complete planning

The planning of a BL20 station should be thorough to avoid faults and increase operating reliability.



Attention

If there are more than two empty slots next to one another, the communication is interrupted to all following BL20 modules.

7.1.2 Maximum system extension

A BL20 station can consist of a gateway and a maximum of 74 modules in slice design (equivalent to 1 m in length of mounting rail including the end bracket and end plate). The maximum number of modules is less when using block modules (1 block module is equivalent to 8 modules in slice design).

The following overview shows the maximum number of channels possible, on condition that the entire station is made up of that respective type of channel only:

	Channels		Modules		
	Type	Max. no.	Type	Max. no.	
<i>Table 7-1: Maximum system extension, process data dependent</i>	A plus 1 Bus Refreshing module	Digital inputs	288	BL20-4DI-24VDC-P	72 B
		Digital outputs	288	BL20-4DO-24VDC-0.5A-P	72 B
	B plus 2 Bus Refreshing modules	Analog inputs, current	126	BL20-2AI-I(0/4...20MA)	63 C
	C plus 3 Bus Refreshing modules	Analog inputs, voltage	126	BL20-2AI-U(-10/0...+10VDC)	63 C
		Analog inputs, PT /NI	126	BL20-2AI-PT/NI-2/3	63 C
		Analog inputs, Thermocouple	126	BL20-2AI-THERMO-PI	63 C
		Analog outputs, current	126	BL20-2AO-I(0/4...20MA)	63 C
		Analog inputs, voltage	126	BL20-2AO-U(-10/0...+10VDC)	63 C
		Counter	31	BL20-1CNT-24VDC	31 A
	RS232	31	BL20-1RS232	31 A	
	RS485/422	31	BL20-1RS485/422	31 A	
	SSI	31	BL20-1SSI	31 A	

Further limitations can be placed on the maximum possible number of BL20 modules by the use of the Power Feeding modules BL20-PF-24VDC-D or BL20-PF-120/230VAC-D; these being used either for creating potential groups or by insufficient field supply.



Attention

Ensure that a sufficient number of Power Feeding or Bus Refreshing modules are used if the system is extended to its maximum.



Note

If the system limits are exceeded, the software I/O-ASSISTANT generates an error message when the user activates the "Station → Verify" command.

7.2 Power supply

7.2.1 Module bus refreshing

The number of BL20 modules that can be supplied by the gateway or a separate Bus Refreshing module via the internal module bus depends on the respective nominal current consumption of the individual modules on the module bus.



Attention

The sum total of the nominal current consumption of the connected BL20 modules must not exceed 1.5 A.

The following examples show the calculation for the required number of Bus Refreshing modules:

Example 1:

The BL20 station consists of 20 BL20-1AI-I(0/4...20MA) modules. The number of additional Bus Refreshing modules required is calculated as follows:

Gateway		430 mA
20 BL20-1AI-I(0/4...20MA)	20 x 41 mA	820 mA
	Total:	1250 mA
Maximum permissible current via module bus:		1 500 mA

The calculation shows that no further Bus Refreshing module is required.

Example 2:

The BL20 station comprises 15 BL20-1AI-U(-10/0...+10VDC) modules, 10 BL20-2AO-U(-10/0...+10VDC) modules, 10 BL20-2DI-24VDC-P modules and 5 BL20-2DO-24VDC-0.5A-P modules. The required number of Bus Refreshing modules is calculated as follows:

Gateway		430 mA
15 BL20-1AI-U(-10/0...+10VDC)	15 x 41 mA	615 mA
10 BL20-2AO-U(-10/0...+10VDC)	10 x 43 mA	430 mA
10 BL20-2DI-24VDC-P	10 x 28 mA	280 mA
5 BL20-2DO-24VDC-0.5A-P	5 x 32 mA	160 mA
	Total:	1 915 mA
Maximum permissible current via module bus:		1 500 mA

The calculation shows that an additional/further Bus Refreshing module is required at the latest following the last BL20-2AO module. This Bus Refreshing module is sufficient to supply the remaining modules.

**Note**

The power requirements of the BL20 gateway is to be considered when calculating the required number of Bus Refreshing modules.

The following table offers an overview of the nominal current consumption of the individual BL20 modules on the module bus:

Table 7-2:
Nominal current
consumption of
the BL20
modules on the
module bus

Module	Supply	Nominal current consumption
Gateway	1 500 mA	430 mA
BL20-PF-24VDC-D		28 mA
BL20-PF-120/230VAC-D		25 mA
BL20-2DI-24VDC-P		28 mA
BL20-2DI-24VDC-N		28 mA
BL20-2DI-120/230VAC		28 mA
BL20-4DI-24VDC-P		29 mA
BL20-4DI-24VDC-N		28 mA
BL20-E-8DI-24VDC-P		15 mA
BL20-16DI-24VDC-P		45 mA
BL20-E-16DI-24VDC-P		15 mA
BL20-32DI-24VDC-P		30 mA
BL20-1AI-I(0/4...20MA)		41 mA
BL20-2AI-I(0/4...20MA)		35 mA
BL20-1AI-U(-10/0...+10VDC)		41 mA
BL20-2AI-U(-10/0...+10VDC)		35 mA
BL20-2AI-PT/NI-2/3		45 mA
BL20-2AI-THERMO-PI		45 mA
BL20-4AI-U/I		50 mA
BL20-2DO-24VDC-0.5A-P		32 mA
BL20-2DO-24VDC-0.5A-N		32 mA

Module	Supply	Nominal current consumption
BL20-2DO-24VDC-2A-P		33 mA
BL20-4DO-24VDC-0.5A-P		30 mA
BL20-E-8DO-24VDC-P		15 mA
BL20-16DO-24VDC-0.5A-P		120 mA
BL20-E-16DO-24VDC-P		25 mA
BL20-32DO-24VDC-0.5A-P		30 mA
BL20-1AO-I(4...20MA)		39 mA
BL20-2AO-I(4...20MA)		40 mA
BL20-2AO-U(-10/0...+10VDC)		43 mA
BL20-2DO-R-NC		28 mA
BL20-2DO-R-NO		28 mA
BL20-2DO-R-CO		28 mA
BL20-1CNT-24VDC		40 mA
BL20-1RS232		140 mA
BL20-1RS485/422		60 mA
BL20-1SSI		50 mA
BL20-2RFID		30 mA
BL20-E-1SWIRE		60 mA

If the power supply from the module bus is not guaranteed, thereby making a further Bus Refreshing module necessary, the software I/O-ASSISTANT generates an error message when the user activates the command "Station → Verify".



Note

Bus Refreshing modules which do not supply the gateway with power are to be combined with either a BL20-P3T-SBB-B or a BL20-P4T-SBBC-B (tension clamp connection) base module or with the base modules BL20-P3S-SBB-B or BL20-P4S-SBBC-B (screw connection).

Figure 7-1:
Power supply of
the station

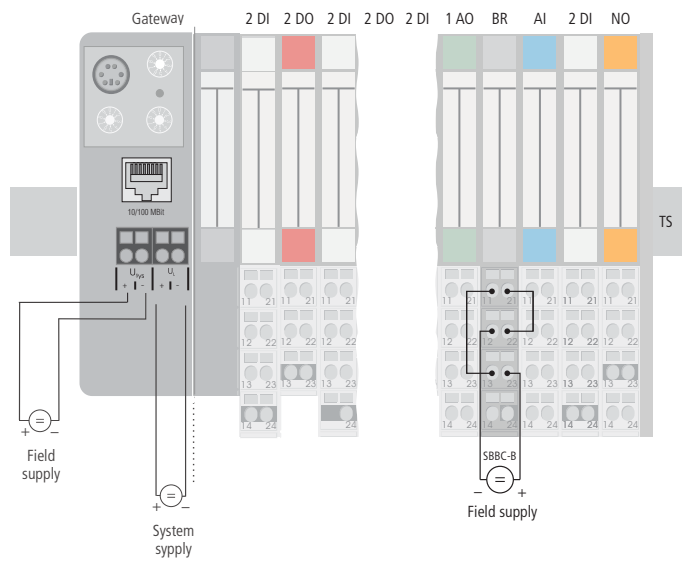

It must be ensured that the same ground potential and ground connections are used. If different ground potentials or ground connections are used, compensating currents flow via the module bus, which can lead to the destruction of the Bus Refreshing module.

All Bus Refreshing modules are connected to one another via the same ground potential.

The power to the module bus is supplied via the connections 11 and 21 on the base module.



Attention

In order to comply with radiation limit values in accordance with EN 55 011/ 2 000, the supply lines of the BL20-BR-24VDC-D module for supplying the gateway with power are to be fed through a ferrite ring (PS416-ZBX-405). This is to be placed immediately next to the connection terminals. From there on, it is not permitted to make connections to further devices.

7.2.2 Creating potential groups

Bus Refreshing and Power Feeding modules can be used to create potential groups. The potential isolation of potential groups to the left of the respective power distribution modules is provided by the base modules.



Attention

Ensure that the correct base modules are planned for when using Bus Refreshing modules.

Figure 7-2:
Example for
creating poten-
tial groups

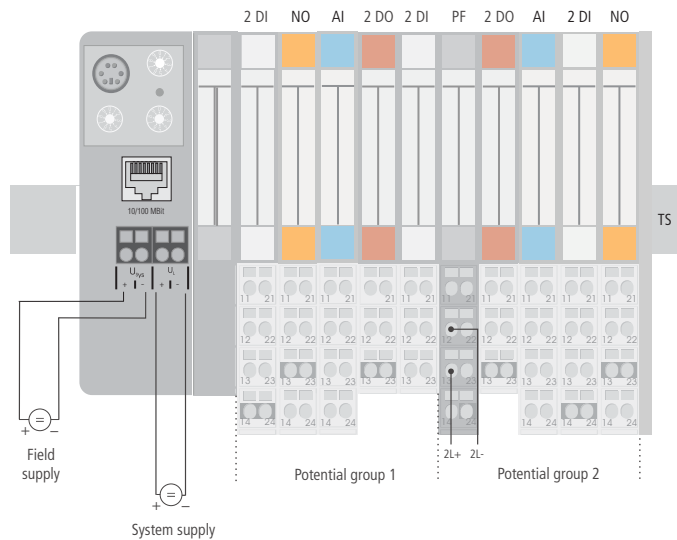

Note

The system can be supplied with power independent of the potential group formation described above.

When using a digital input module for 120/230 V AC, it should be ensured that a potential group is created in conjunction with the Power Feeding module BL20-PF-120/230VAC-D.



Attention

It is not permitted to use the modules with 24 V DC and 120/230 V AC field supply in a joint potential group.

7.2.3 Protecting the service interface on the gateway

During operation, the cover protecting the service interface and the hexadecimal rotary coding-switches must remain closed due to EMC and ESD.

7.2.4 C-Rail (cross connection)

The C-rail runs through all base modules. The C-rail of the base modules for power distribution modules is mechanically separated; thus potentially isolating the adjoining supply groups.

Access to the C-rail is possible with the help of base modules with a C in their designation (for example, BL20-S4T-SBCS). The corresponding connection level is indicated on these modules by a thick black line. The black line is continuous on all I/O modules. On power distribution modules, the black line is

only above the connection 24. This makes clear that the C-rail is separated from the adjoining potential group to its left.

Figure 7-3:
C-rail front view

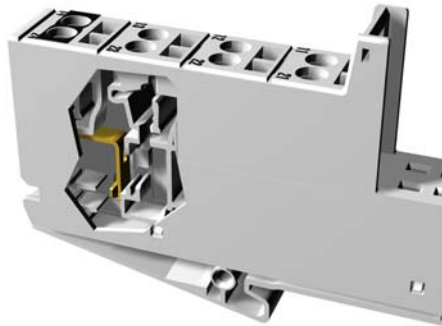

Figure 7-4:
C-rail side view

**Attention**

It is permitted to load the C-rail with a maximum of 24 V. Not 230 V!

The C-rail can be used as required by the application, for example, as a protective earth (PE). In this case, the PE connection of each power distribution module must be connected to the mounting rail via an additional PE terminal, which is available as an accessory.

**Note**

For information about introducing a BL20 station into a ground reference system, please read Chapter 7.

*Figure 7-5:
Using the C-rail as a protective earth*

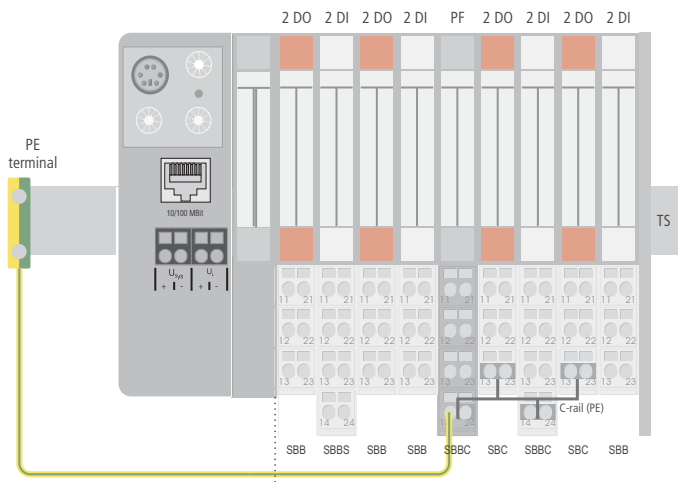

C-rails can be used for a common voltage supply when relay modules are planned. To accomplish this, the load voltage is connected to a Power Feeding module with the BL20-P4x-SBBC base module with tension clamp or screw connection. All the following relay modules are then supplied with power via the C-rail.



Attention

When relay modules are planned and the C-rail is used for a common voltage supply, a further power distribution module must be used for the potential isolation to the following modules. The C-rail can only again be used as a PE following potential isolation.

*Figure 7-6:
Using the C-rail as protective earth and for the power supply with relay modules*

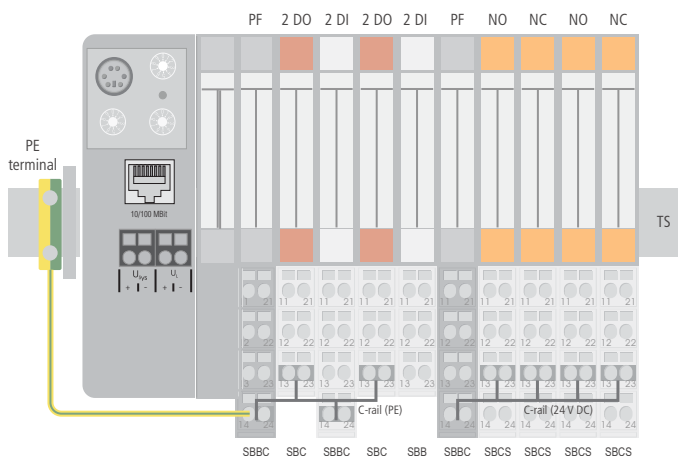

Cross-connecting relay module roots is achieved by the use of jumpers. The corresponding connection diagrams can be found in the manuals for the BL20 I/O modules (German: D300716, English: D300717).

7.2.5 Direct wiring of relay modules

As well as the options mentioned above, relay modules can be wired directly. In this case, base modules without C-rail connections should be chosen to guarantee the potential isolation to the adjoining modules.

7.3 Plugging and pulling electronics modules

BL20 enables the pulling and plugging of electronics modules without having to disconnect the field wiring. The BL20 station remains in operation if an electronics module is pulled. The voltage and current supplies as well as the protective earth connections are not interrupted.



Attention

If the field and system supplies remain connected when electronics modules are plugged or pulled, short interruptions to the module bus communications can occur in the BL20 station. This can lead to undefined statuses of individual inputs and outputs of different modules.

7.4 Extending an existing station



Attention

Please note that extensions to the station (mounting further modules) should be carried out only when the station is in a voltage-free state.

7.5 Firmware download

Firmware can be downloaded via the service interface on the gateway using the software tool I/O-ASSISTANT. More information is available in the program's online help.



Attention

The station should be disconnected from the fieldbus when downloading.
Firmware must be downloaded by authorized personnel only.
The field level must be isolated.

Guidelines for station planning

8 Guidelines for electrical installation

8.1	General notes	2
8.1.1	General	2
8.1.2	Cable routing	2
8.1.3	Cable routing inside and outside of cabinets	2
	– Cable routing outside buildings	3
8.1.4	Lightning protection	3
8.1.5	Transmission media	4
8.2	Potential relationships	5
8.2.1	General	5
8.3	Electromagnetic Compatibility (EMC)	6
8.3.1	Ensuring EMC	6
8.3.2	Grounding of inactive metal components	6
8.3.3	PE connection	6
8.3.4	Earth-free operation	6
8.3.5	Mounting rails	7
8.4	Shielding of cables	8
8.5	Potential compensation	9
8.5.1	Switching inductive loads	9
8.5.2	Protection against Electrostatic Discharge (ESD)	9

8.1 General notes

8.1.1 General

Cables should be grouped together, for example: signal cables, data cables, heavy current cables, power supply cables.

Heavy current cables and signal or data cables should always be routed in separate cable ducts or bundles. Signal and data cables must always be routed as close as possible to ground potential surfaces (for example support bars, cabinet sides etc.).

8.1.2 Cable routing

Correct cable routing prevents or suppresses the reciprocal influencing of parallel routed cables.

8.1.3 Cable routing inside and outside of cabinets

To ensure EMC-compatible cable routing, the cables should be grouped as follows:

Various types of cables within the groups can be routed together in bundles or in cable ducts.

Group 1:

- shielded bus and data cables
- shielded analog cables
- unshielded cables for DC voltage ≤ 60 V
- unshielded cables for AC voltage ≤ 25 V

Group 2:

- unshielded cables for DC voltage > 60 V and ≤ 400 V
- unshielded cables for AC voltage > 25 V and ≤ 400 V

Group 3:

- unshielded cables for DC and AC voltages > 400 V

The following group combination can be routed only in separate bundles or separate cable ducts (no minimum distance apart):

- **Group 1/Group 2**

The group combinations:

- **Group 1/Group 3 and Group 2/Group 3**

must be routed in separate cable ducts with a minimum distance of 10 cm apart. This is equally valid for inside buildings as well as for inside and outside of switchgear cabinets.

Cable routing outside buildings

Outside of buildings, cables should be routed in closed (where possible), cage-type cable ducts made of metal. The cable duct joints must be electrically connected and the cable ducts must be earthed.



Attention

Observe all valid guidelines concerning internal and external lightning protection and grounding specifications when routing cables outside of buildings.

8.1.4 Lightning protection

The cables must be routed in double-grounded metal piping or in reinforced concrete cable ducts.

Signal cables must be protected against overvoltage by varistors or inert-gas filled overvoltage arrestors. Varistors and overvoltage arrestors must be installed at the point where the cables enter the building.

8.1.5 Transmission media

For a communication via Ethernet, different transmission media can be used:

- coaxial cable
10Base2 (thin koax),
10Base5 (thick koax, yellow cable)
- optical fibre (10BaseF)
- twisted two-wire cable (10BaseT) with shielding (STP) or without shielding (UTP).



Note

TURCK offers a variety of cable types for fieldbus lines as premoulded or bulk cables with different connectors.

The ordering information for the available cable types can be found under www.turck.com.

8.2 Potential relationships

8.2.1 General

The potential relationship of a Ethernet system realized with BL20 modules is characterized by the following:

- The system supply of gateway and I/O-modules as well as the field supply are realized via one power feed at the gateway.
- All BL20 modules (gateway, Power Feeding and I/O-modules), are connected capacitively via base modules to the mounting rails.

The block diagram shows the arrangement of a typical BL20 station.

Figure 8-1:
Block diagram
of a BL20 station

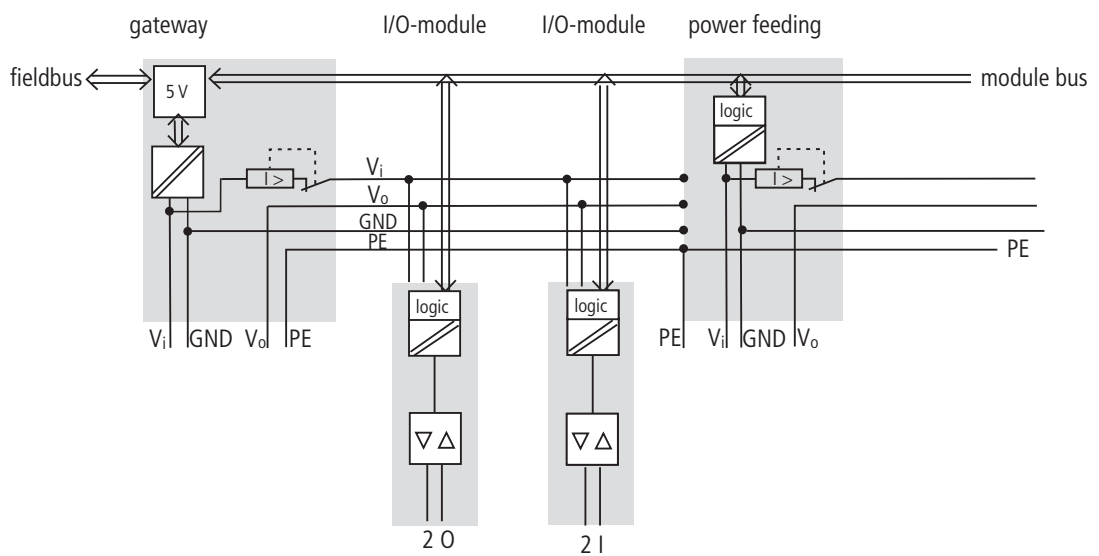

8.3 Electromagnetic Compatibility (EMC)

BL20 products comply in full with the requirements pertaining to EMC regulations.

Nevertheless, an EMC plan should be made before installation. Hereby, all potential electromechanical sources of interference should be considered such as galvanic, inductive and capacitive couplings as well as radiation couplings.

8.3.1 Ensuring EMC

The EMC of BL20 modules is guaranteed when the following basic rules are adhered to:

- Correct and large surface grounding of inactive metal components.
- Correct shielding of cables and devices.
- Proper cable routing – correct wiring.
- Creation of a standard reference potential and grounding of all electrically operated devices.
- Special EMC measures for special applications.

8.3.2 Grounding of inactive metal components

All inactive metal components (for example: switchgear cabinets, switchgear cabinet doors, supporting bars, mounting plates, top hat rails, etc.) must be connected to one another over a large surface area and with a low impedance (grounding). This guarantees a standardized reference potential area for all control elements and reduces the influence of coupled disturbances.

- In the areas of screw connections, the painted, anodized or isolated metal components must be freed of the isolating layer. Protect the points of contact against rust.
- Connect all free moving groundable components (cabinet doors, separate mounting plates, etc.) by using short bonding straps to large surface areas.
- Avoid the use of aluminum components, as its quick oxidizing properties make it unsuitable for grounding.



Danger

The grounding must never – including cases of error – take on a dangerous touch potential. For this reason, always protect the ground potential with a protective cable.

8.3.3 PE connection

A central connection must be established between ground and PE connection (protective earth).

8.3.4 Earth-free operation

Observe all relevant safety regulations when operating an earth free system.

8.3.5 Mounting rails

All mounting rails must be mounted onto the mounting plate with a low impedance, over a large surface area, and must be correctly earthed.

Figure 8-2:
Mounting options

A TS 35
B Mounting rail
C Mounting plate

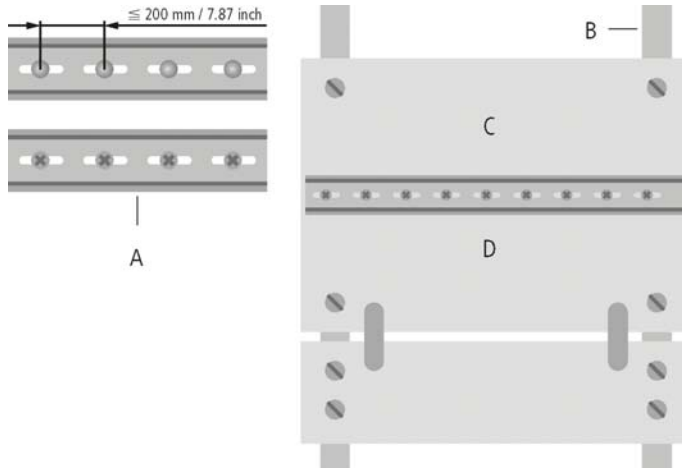

Mount the mounting rails over a large surface area and with a low impedance to the support system using screws or rivets.

Remove the isolating layer from all painted, anodized or isolated metal components at the connection point. Protect the connection point against corrosion (for example with grease; caution: use only suitable grease).

8.4 Shielding of cables

Shielding is used to prevent interference from voltages and the radiation of interference fields by cables. Therefore, use only shielded cables with shielding braids made from good conducting materials (copper or aluminum) with a minimum degree of coverage of 80 %.

The cable shield should always be connected to both sides of the respective reference potential (if no exception is made, for example, such as high-resistant, symmetrical, analog signal cables). Only then can the cable shield attain the best results possible against electrical and magnetic fields.

A one-sided shield connection merely achieves an isolation against electrical fields.



Attention

When installing, please pay attention to the following...

- the shield should be connected immediately when entering the system,
- the shield connection to the shield rail should be of low impedance,
- the stripped cable-ends are to be kept as short as possible,
- the cable shield is not to be used as a bonding conductor.

If the data cable is connected via a SUB-D connector, the shielding should never be connected via pin 1, but to the mass collar of the plug-in connector.

The insulation of the shielded data-cable should be stripped and connected to the shield rail when the system is not in operation. The connection and securing of the shield should be made using metal shield clamps. The shield clamps must enclose the shielding braid and in so doing create a large surface contact area. The shield rail must have a low impedance (for example, fixing points of 10 to 20 cm apart) and be connected to a reference potential area.

The cable shield should not be severed, but routed further within the system (for example, to the switchgear cabinet), right up to the interface connection.



Note

Should it not be possible to ground the shield on both sides due to switching arrangements or device specific reasons, then it is possible to route the second cable shield side to the local reference potential via a capacitor (short connection distances). If necessary, a varistor or resistor can be connected parallel to the capacitor, to prevent disruptive discharges when interference pulses occur.

A further possibility is a double-shielded cable (galvanically separated), whereby the innermost shield is connected on one side and the outermost shield is connected on both sides.

8.5 Potential compensation

Potential differences can occur between installation components that are in separate areas and these

- are fed by different supplies,
- have double-sided conductor shields which are grounded on different installation components.

A potential-compensation cable must be routed to the potential compensation.



Danger

Never use the shield as a potential compensation.

A potential compensation cable must have the following characteristics:

- Low impedance. In the case of compensation cables that are routed on both sides, the compensation line impedance must be considerably smaller than that of the shield connection (max. 10 % of shield connection impedance).
- Should the length of the compensation cable be less than 200 m, then its cross-section must be at least $16 \text{ mm}^2 / 0.025 \text{ inch}^2$. If the cable length is greater than 200 m, then a cross-section of at least $25 \text{ mm}^2 / 0.039 \text{ inch}^2$ is required.
- The compensation cable must be made of copper or zinc coated steel.
- The compensation cable must be connected to the protective conductor over a large surface area and must be protected against corrosion.
- Compensation cables and data cables should be routed as close together as possible, meaning the enclosed area should be kept as small as possible.

8.5.1 Switching inductive loads

In the case of inductive loads, a protective circuit on the load is recommended.

8.5.2 Protection against Electrostatic Discharge (ESD)



Attention

Electronic modules and base modules are at risk from electrostatic discharge when disassembled. Avoid touching the bus connections with bare fingers as this can lead to ESD damage.

Guidelines for electrical installation

9 BL20-Approvals for Zone 2/ Division 2



Note

The Zone 2 - approval certificates for BL20 can be found in a separate manual for approvals D301255 on www.turck.de.

10 Appendix

10.1	Data image of the technology modules	2
10.1.1	Counter module	2
	– Process input data - counter mode.....	2
	– Process input data - measurement mode.....	4
	– Process output data - counter mode	6
	– Process output data - measurement mode	10
10.1.2	RSxxx-module	13
	– Process input data	13
	– Process output data	15
10.1.3	SSI-module.....	17
	– Process input data	17
	– Process output data (PDout)	20
10.2	Nominal current consumption and power loss	22
10.3	Power loss of the modules	26

10.1 Data image of the technology modules

10.1.1 Counter module

Process input data - counter mode

Process input data is data from the connected field device that is transmitted via the BL20-1CNT-24VDC module to the PLC. This is transferred in an 8-byte format as follows:

- 4 bytes are used to represent the counter value.
- 1 byte contains the diagnostics data.
- 2 bytes contain status information.

Figure 10-1:
PZDE counter,
counter mode

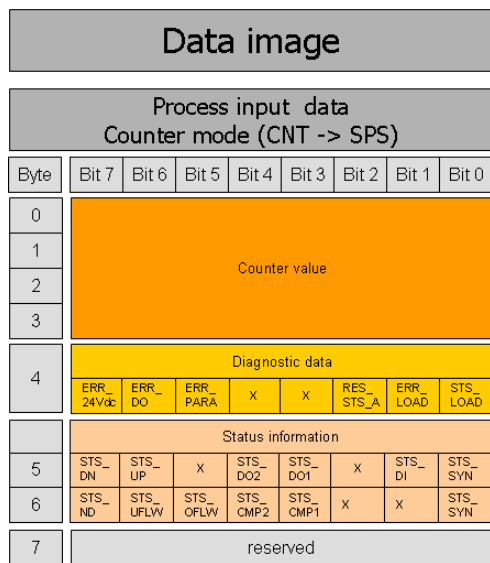

Table 10-1:
Meaning of the
data bits (process
input)

Bits	Explanations
ERR_24Vdc	Short-circuit sensor supply This diagnostics information must be acknowledged with the EXTF_ACK (process output) control bit.
ERR_DO	Short-/open circuit/excess temperature at the output DO1 This diagnostics information must be acknowledged with the EXTF_ACK (process output) control bit.
ERR_PARA	- 1: There is a parameter error. ERR_PARA is a group diagnostics bit. With the separate diagnostics message bits 3 to 6 describe the parameter errors in more detail. - 0: The parameter definition is correct as per specification.
RES_STS_A	- 1: Resetting of status bits running. The last process output telegram contained: RES_STS = 1. - 0: The last process output telegram contained: RES_STS = 0.
ERR_LOAD	- 1: Error with load function Control bits LOAD_DO_PARAM, LOAD_CMP_VAL2, LOAD_CMP_VAL1, LOAD_PREPARE and LOAD_VAL must not be set at the same time during the transfer. An incorrect value was transferred with the control bits. Example: Values above the upper count limit or below the lower count limit were selected for Load value direct or Load value in preparation.
STS_LOAD	Status of load function Set if the Load function is running.
STS_DN	1: Status direction down.
STS_UP	1: Status direction up.
STS_DO2	The DO2 status bit indicates the status of digital output DO2.
STS_DO1	The DO1 status bit indicates the status of digital output DO1.
STS_DI	The DI status bit indicates the status of digital input DI.
STS_GATE	1: Counting operation running.
STS_ND	Status zero crossing Set on crossing zero in counter range when counting without main direction. This bit must be reset by the RES_STS control bit.
STS_UFLW	Status lower count limit Set if the count value goes below the lower count limit. This bit must be reset by the RES_STS control bit.
STS_OFLW	Status upper count limit Set if the counter goes above the upper count limit. This bit must be reset by the RES_STS control bit.

Table 10-1:
Meaning of the
data bits (process
input)

Bits	Explanations
STS_CMP2	<p>Status comparator 2</p> <p>This status bit indicates a comparison result for comparator 2 if:</p> <ul style="list-style-type: none"> - The output DO2 is released with CTRL_DO2 = 1. and - a comparison is run via MODE_DO2 = 01, 10 or 11. <p>Otherwise STS_CMP2 simply indicates that the output is or was set. STS_CMP2 is also set if DO2 SET_DO2 = 1 when the output is not released.</p> <p>This bit must be reset by the RES_STS control bit.</p>
STS_CMP1	<p>Status comparator 1</p> <p>This status bit indicates a comparison result for comparator 1 if:</p> <ul style="list-style-type: none"> - The output DO1 is released with CTRL_DO1 = 1. and - a comparison is run via MODE_DO1 = 01, 10 or 11. <p>Otherwise STS_CMP1 simply indicates that the output is or was set. It must be acknowledged with RES_STS (process output). The bit is reset immediately if acknowledgement takes place when the output is still set. STS_CMP1 is also set if DO1 SET_DO1 = 1 when the output is not released.</p> <p>This bit must be reset by the RES_STS control bit.</p>
STS_SYN	<p>Status synchronization</p> <p>After synchronization is successfully completed the STS_SYN status bit is set.</p> <p>This bit must be reset by the RES_STS control bit.</p>

Process input data - measurement mode

- 4 bytes contain the measurement value
- 1 byte contains diagnosis information
- 2 bytes contain status messages

Figure 10-2:
PZDE counter,
measurement
mode

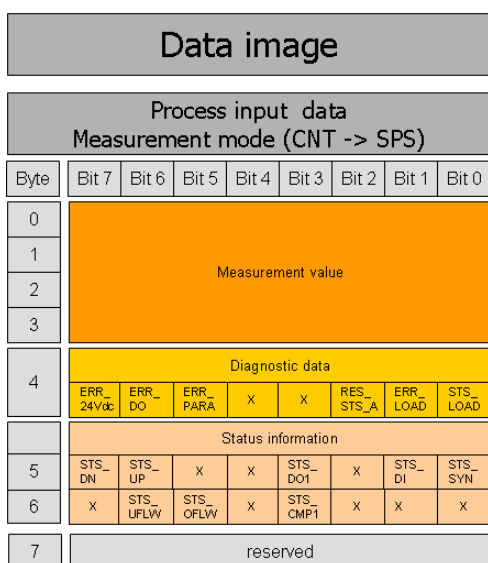

Table 10-2:
Meaning of the
data bits (process
input)

Bits	Explanations
ERR_24Vdc	Short-circuit sensor supply This diagnostics information must be acknowledged with the EXTF_ACK (process output) control bit.
ERR_DO	Short-/open circuit/excess temperature at the output DO1
ERR_PARA	- 1: There is a parameter error. ERR_PARA is a group diagnostics bit. With the separate diagnostics message bits 3 to 6 describe the parameter errors in more detail. - 0: The parameter definition is correct as per specification.
RES_STS_A	- 1: Resetting of status bits running. The last process output telegram contained: RES_STS = 1. - 0: The last process output telegram contained: RES_STS = 0.
ERR_LOAD	1: Error with load function The control bits LOAD_UPLIMIT and LOAD_LOLIMIT must not be set simultaneously during the transfer. The value of LOAD_UPLIMIT and LOAD_LOLIMIT was selected outside of the permissible range. Permissible values for LOAD_LOLIMIT: 0 to 199 999 999 x 10 ⁻³ Hz 0 to 24 999 999 x 10 ⁻³ rpm 0 to 99 999 999 ms Permissible values for LOAD_UPLIMIT: 1 to 200 000 000 x 10 ⁻³ Hz 1 to 25 000 000 x 10 ⁻³ rpm 1 to 100 000 000 ms
STS_LOAD	Status of load function Set if the Load function is running.
STS_DN	Direction status: down. The direction is determined by a signal at the physical input B. The Signal evaluation parameter (A, B): must be set to pulse and direction.
STS_UP	Direction status: up. The direction is determined by a signal at the physical input B. The Signal evaluation parameter (A, B): must be set to pulse and direction.
STS_DO1	The DO1 status bit indicates the status of digital output DO1.
STS_DI	The DI status bit indicates the status of digital input DI.
STS_GATE	1: Measuring operation running.
STS_UFLW	1: The lower measuring limit was undershot. The bit must be reset with RES_STS: 0 → 1.
STS_OFLW	1: The upper measuring limit was exceeded. The bit must be reset with RES_STS: 0 → 1.

Table 10-2:
Meaning of the
data bits (process
input)

Bits	Explanations
STS_CMP1	1: Measuring terminated^ The measured value is updated with every elapsed time interval. The end of a measurement (expiry of the time interval) is indicated with the status bit STS_CMP1. The bit must be reset with RES_STS: 0 → 1.

Process output data - counter mode

The process output data is the data that is output from the PLC via the gateway to the BL20-1CNT-24VDC module.

The BL20 module allows some parameters to be modified during operation.

The other parameters must be changed prior to commissioning.



Note

The current count operation is stopped if parameters are changed during operation.



Note

The parameters modified via the process output data are not retentive. The commissioning after a power failure is based on the parameter data of the configuration tool or default configuration.

The data is transferred in 8 byte format:

- Two control bytes contain the control functions for transferring the parameter values, for starting/ stopping the measurement, for acknowledging errors and for resetting the status bit.
- Four bytes provide the parameter values for "Load direct", "Load in preparation", "Reference value 1", "Reference value 2" or "Behavior of the digital outputs".

Structure of the data bytes with
 "Load value direct"
 "Load value in preparation",
 "Reference value 1" or
 "Reference value 2"

Figure 10-3:
 Structure of the data bytes with "Load value direct", "Load value in preparation", "Reference value 1" or "Reference value 2"

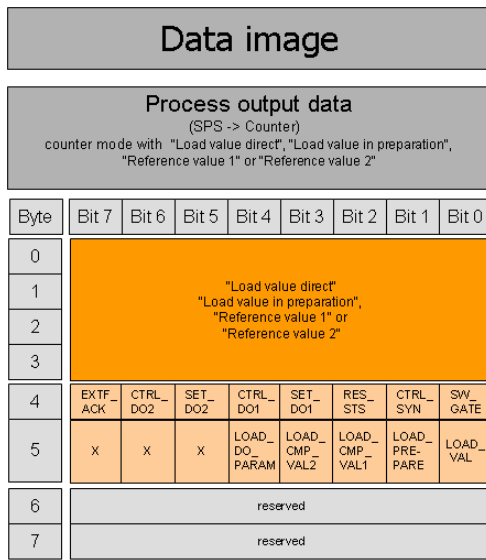

Structure of the data bytes with "Function and behavior of DO1/DO2"

Figure 10-4:
 Structure of the data bytes with "Function and behavior of DO1/DO2"

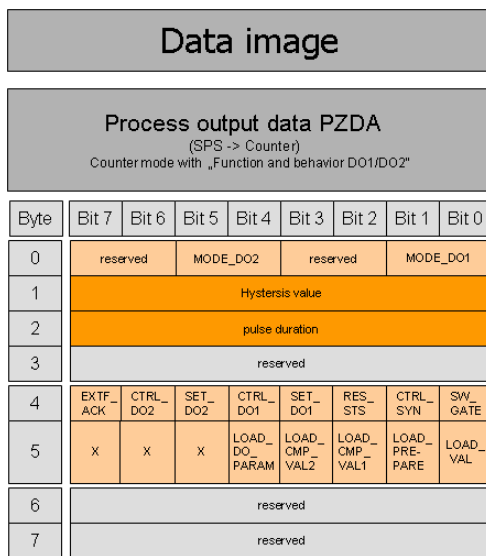

Table 10-3:
Meaning of the
data bits (process
output)

	Control bit	Explanations
A Unlike the physical digital output DO1, output DO2 is only a data value that is indicated with the data bit STS_DO2 of the process input.	MODE_DO2	<p>Only valid if LOAD_DO_PARAM: "0" → "1".</p> <p>The virtual A output DO2 can show the status of the data bit SET_DO2 or comparison results if CTRL_DO2 = 1.</p> <p>MODE_DO2 defines which function DO2 is to accept:</p> <ul style="list-style-type: none"> - 00: The output DO2 shows the status of the control bit SET_DO2. This must be released with CTRL_DO2 = 1. - 01: Output DO2 indicates: Counter status ≥ reference value 2 - 10: Output DO2 indicates: Counter status ≤ reference value 2 - 11: Output DO2 indicates: Counter status = reference value 2 <p>A pulse is generated for indicating equal values. The pulse duration is defined by byte 2 of this process output.s</p>
	MODE_DO1	<p>Only valid if LOAD_DO_PARAM: "0" → "1".</p> <p>The physical output DO1 can show the status of the data bit SET_DO1 or comparison results if CTRL_DO1 = 1.</p> <p>MODE_DO1 defines which function DO1 is to accept:</p> <ul style="list-style-type: none"> - 00: The output DO1 shows the status of the control bit SET_DO1. This must be released with CTRL_DO1 = 1. - 01: Output DO1 indicates: Counter status ≥ reference value 1 - 10: Output DO1 indicates: Counter status ≤ reference value 1 - 11: Output DO1 indicates: Counter status = reference value 1 <p>A pulse is generated for indicating equal values. The pulse duration is defined by byte 2 of this process output.</p>
	Hysteresis value	<p>(0 to 255)</p> <p>The reference value 1/2 can be assigned a hysteresis value in order to generate a response at DO1/DO2 with hysteresis. This will prevent the excessive on and off switching of DO1/DO2 if the count value fluctuates too quickly around the reference value.</p>
	Pulse duration	<p>(0 to 255) unit: ms</p> <p>If the DO1/DO2 outputs are set to indicate counter status = reference value 1/2, a longer pulse is sometimes required to indicate equal values.</p>
	EXTF_ACK	<p>Error acknowledgement</p> <p>The error bits must be acknowledged with the control bit EXTF_ACK after the cause of the fault has been rectified. This control bit must then be reset again. Any new error messages are not set while the EXTF_ACK control bit is set!</p>
	CTRL_DO2	<p>0: The virtual A output DO2 is blocked.</p> <p>1: The virtual A output DO2 is released.</p>

Table 10-3:
Meaning of the
data bits (process
output)

Control bit	Explanations
SET_DO2	If CTRL_DO2 = 1 and the virtual A output DO2 is set to indicate the value SET_DO2, DO2 can be set and reset directly with SET_DO2. DO2 can be set for this function via the process output (MODE_DO2 = 00 and LOAD_DO_PARAM "0" → "1"). The output DO2 can also be set before commissioning via the separate parameter data. The default setting for DO2 is to indicate the status of SET_DO2.
CTRL_DO1	0: The output DO1 is blocked. 1: The output DO1 is released.
SET_DO1	If CTRL_DO1 = 1 and the physical output DO1 is set to indicate the value SET_DO1, DO1 can be set and reset directly with SET_DO1. DO1 can be set for this function via the process output (MODE_DO1 = 00 and LOAD_DO_PARAM "0" → "1"). The output DO2 can also be set before commissioning via the separate parameter data. The default setting for DO1 is to display the value of SET_DO1.
RES_STS	"0" → "1" Initiate resetting of status bits. Status bits STS_ND, STS_UFLW, STS_OFLW, STS_CMP2, STS_CMP1, STS_SYN (process input) are reset. Bit RES_STS_A = 1 (process input) acknowledges that the reset command has been received. RES_STS can now be reset to 0.
CTRL_SYN	Release synchronization 1: "0" → "1" (rising edge) at the physical DI input enables the counter value to be set (synchronized) once/periodically to the load value.
SW_GATE	"0" → "1": Counting is started (release). "1" → "0": Counting is stopped. The starting and stopping of the counting operation with a data bit is implemented with a so-called "SW gate". The HW gate is also provided in addition for stopping and starting the counting operation via the DI hardware input. If this function is configured a positive signal must be present at this input in order to activate the SW gate (AND logic operation).
LOAD_DO_PARAM	Parameter definition of the DO1 physical output and the virtual A DO2 output "0" → "1": DO1 and DO2 can indicate the status of data bit SET_DO1 and SET_DO2 or comparison results. The latest telegram (MODE_DO1 and MODE_DO2) indicates the function required for DO1 and DO2.
LOAD_CMP_VAL2	Parameter definition of reference value 2 "0" → "1": The value in bytes 0 to 3 is accepted as a reference value 2.
LOAD_CMP_VAL1	Parameter definition of reference value 1 "0" → "1": The value in bytes 0 to 3 is accepted as a reference value 1.
LOAD_PREPARE	Parameter definition of Load counter in preparation "0" → "1": The value in bytes 0 to 3 is accepted as the new load value.
LOAD_VAL	Parameter definition of Load counter direct "0" → "1": The value in bytes 0 to 3 is accepted directly as the new count value.

Process output data - measurement mode

The data is transferred in 8 byte format:

- Two control bytes contain the control functions for transferring the parameter values, for starting/stopping the measurement, for acknowledging errors and for resetting the status bit.
- Four bytes represent the parameter values for Lower limit or Upper limit, Function of DO1 or Integration time.

Structure of the data bytes with „Function of DO1“ set

Figure 10-5:
Structure of the data bytes with „Function of DO1“ set

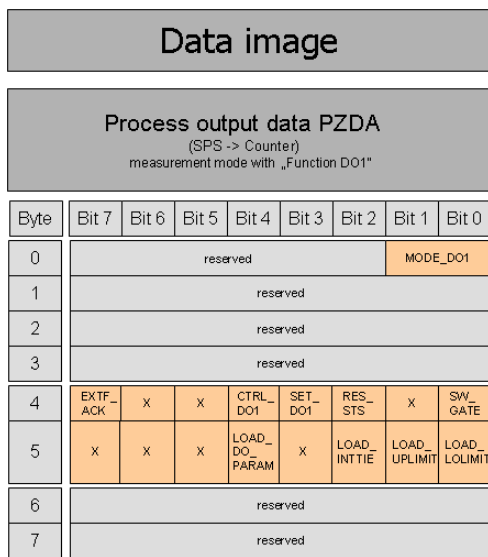

Structure of the data bytes with „Lower limit“ or „Upper limit“ set

Figure 10-6:
Structure of the data bytes with „Lower limit“ or „Upper limit“ set

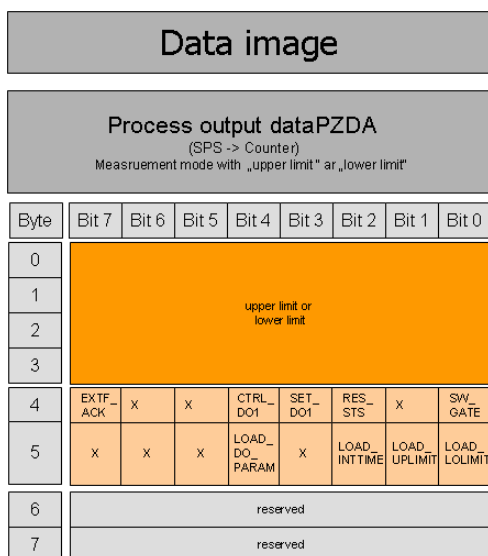

Structure of the data bytes with „Integration time set“

Figure 10-7:
Structure of the data bytes with „Integration time set“

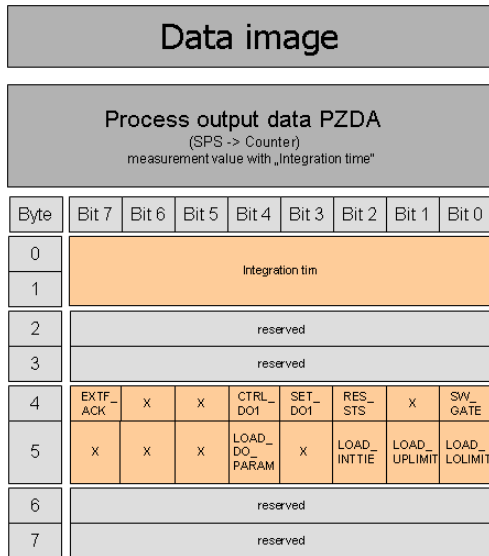

Table 10-4:
Meaning of the data bits (process output)

Control bit	Explanations
EXTF_ACK	Error acknowledgement The ERR_DO or ERR_24Vdc error bits must be acknowledged with the control bit EXTF_ACK after the cause of the fault has been rectified. This control bit must then be reset again. Any new error messages are not set while the EXTF_ACK control bit is set!
CTRL_DO1	- 0: The output DO1 is blocked. - 1: The output DO1 is released.
SET_DO1	If CTRL_DO1 = 1 and the physical output DO1 is configured for indicating the value SET_DO1, DO1 can be set and reset directly with SET_DO1. DO1 can be set for this function via the process output (MODE_DO1 = 00 and LOAD_DO_PARAM 0 → 1). The output DO1 can also be set before commissioning via the separate parameter data. The default setting for DO1 is to display the value of SET_DO1.
RES_STS	0 → 1 Initiate resetting of status bits. The STS_UFLW, STS_OFLW and STS_CMP1 (process input) status bits are reset. Bit RES_STS_A = 1 (process input) acknowledges that the reset command has been received. RES_STS can now be reset to 0.
SW_GATE	0 → 1: Measuring is started (software release). 1 → 0: Measuring is stopped.
LOAD_DO_PARAM	Parameter setting of the physical output DO1 0 → 1: DO1 can indicate the status of different data bits as a signal. The current telegram (byte 0) determines the data bits to which DO1 is to refer.

Table 10-4:
Meaning of the
data bits (process
output)

Control bit	Explanations
LOAD_INTTIME	<p>Parameter setting of the Integration time</p> <p>0 → 1: Bytes 0 to 1 of this process output represent a factor for forming the Integration time for frequency measurement and for determining the rotational speed. The integration time can be adjusted between 10 ms and 10 s in 10 ms increments and is produced by multiplying the factor x 10 ms.</p> <p>With period duration measurement, this factor determines the number of periods measured in order to calculate a mean value.</p> <p>A factor 1 to 1000 (1hex to 3E8hex) is permissible.</p>
LOAD_UPLIMIT	<p>Parameter setting of the upper measuring limit</p> <p>0 → 1: The value in bytes 0 to 3 is accepted directly as the new upper measuring limit. LOAD_UPLIMIT:</p> <p>1 to 200 000 000 x 10⁻³ Hz</p> <p>1 to 25 000 000 x 10⁻³ rpm</p> <p>1 to 100 000 000 ms</p>
LOAD_LOPLIMIT	<p>Parameter setting of the lower measuring limit</p> <p>0 A 1: The value in bytes 0 to 3 is accepted directly as the new lower measuring limit.</p> <p>LOAD_LOLIMIT:</p> <p>0 to 199 999 999 x10⁻³ Hz</p> <p>0 to 24 999 999 x 10⁻³ rpm</p> <p>0 to 99 999 999 ms</p>
MODE_DO1	<p>MODE_DO1 is only valid if LOAD_DO_PARAM: 0 → 1. The physical output DO1 can show the status of the data bit SET_DO1 or comparison results if CTRL_DO1 = 1.</p> <p>MODE_DO1 defines which function DO1 is to accept:</p> <ul style="list-style-type: none"> - 00: The output DO1 indicates the status of the control bit SET_DO1. - 01: The output DO1 indicates a measurement outside of the limits, i.e. above the upper measuring limit or below the lower measuring limit. STS_OFLW = 1 or STS_UFLW = 1 (process input). - 10: Output DO1 indicates a value below the lower measuring limit. STS_UFLW = 1 (process input) - 11:Output DO1 indicates a value above the upper measuring limit. STS_OFLW = 1 (process input)

10.1.2 RSxxx-module

Process input data

The incoming data are stored in the receive-buffer of the BL20-1RSxxx module, segmented and transferred to the PLC via the module bus and the gateway.

The transmission is realized in a 8-byte format, structured as follows:

- 1 status byte, used to guarantee error free data-transmission.
- 1 byte diagnostic data
- 6 byte user data

Figure 10-8:
Data image PLC
input data

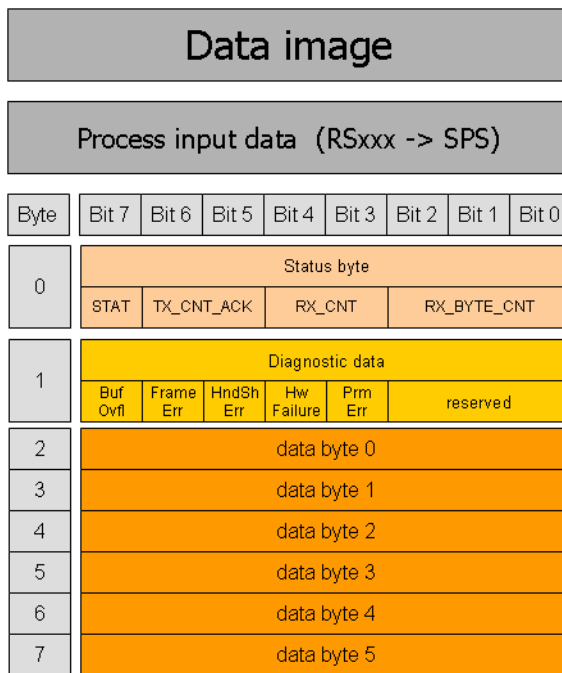

Table 10-5:
Meaning of the
data bits
(process input)

Designation	Value	Meaning
BufOvfl; FrameErr; HndShErr; HwFailure; PrmErr	0 - 255	Diagnostic information (correspond to the diagnostic information in the diagnosis telegram). These diagnostics are always displayed and independent to the setting of the parameter „Diagnostics“.
STAT	0-1	1: The communication with the data terminal equipment (DTE) is error free 0: The communication with the data terminal equipment (DTE) is disturbed. A diagnosis message is generated if the parameter „Diagnostics“ is set to „0/ release“. The diagnostic data show the cause of the communication disturbance. The user has to set back this bit in the process output data by using STATRES.
TX_CNT_ACK	0-3	The value TX_CNT_ACK is a copy of the value TX_CNT. TX_CNT has been transmitted together with the last data segment of the process output data. TX_CNT_ACK is an acknowledge for the successful transmission of the data segment with TX_CNT.
RX_CNT	0-3	This value is transferred together with every data segment. The RX_CNT values are sequential: 00->01->10->11->00... (decimal: 0->1->2->3->0...) Errors in this sequence show the loss of data segments.
RX_BYTE_CNT	0-7	Number of the valid bytes in this data segment.

Process output data

Process output data are data which are sent from the PLC via the gateway and the BL20-1RSxxx module to a connected field device.

The data received from the PLC are loaded into the transmit- buffer in the BL20-1RSxxx module.

The transmission is realized in a 8-byte format which is structured as follows:

- 1 control byte, used to guarantee error free data-transmission.
- 1 byte containing signals to flush the transmit- and receive buffer.
- 6 byte user data

Figure 10-9:
Process output
data

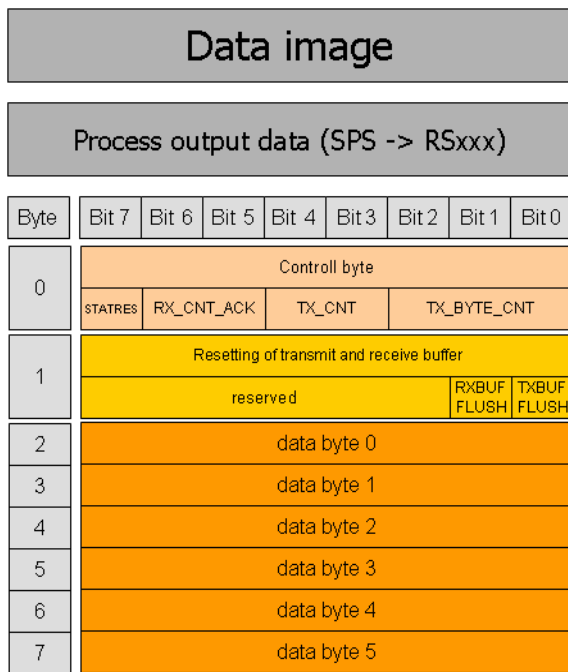

Table 10-6:
Meaning of the
data bits
(process output)

Designation	Value	Meaning
RXBUF FLUSH	0 - 1	This bit is used to flush the receive-buffer. If STATRES = 1: The command RXBUF FLUSH = 1 is ignored. If STATRES = 0: RXBUF FLUSH = 1 causes the flushing of the receive-buffer.
TXBUF FLUSH	0-1	This bit is used to flush the transmit-buffer. If STATRES = 1: The command TXBUF FLUSH = 1 is ignored. If STATRES = 0: TXBUF FLUSH = 1 causes the flushing of the tranceive-buffer.
STATRES	0-1	This bit is set to reset the STAT bit in the process input data. With the change from 1 to 0 the STAT bit is reset (from 0 to 1). If this bit is 0, all changes in TX_BYTE_CNT, TX_CNT and RX_CNT_ACK are ignored. Flushing the transmit-/ receive-buffer with RXBUF FLUSH/ TXBUF FLUSH is possible. If this bit is 1 or with the change from 0 to 1, the flushing of the transmit-/ receive-buffer with RXBUF FLUSH/ TXBUF FLUSH is not possible.
RX_CNT_ACK	0-3	The value RX_CNT_ACK is a copy of the value RX_CNT. TX_CNT has been transmitted together with the last data segment of the process input data. TX_CNT_ACK is an acknowledge for the successful transmission of the data segment with RX_CNT.
TX_CNT	0-3	This value is transferred together with every data segment. The TX_CNT values are sequential: 00->01->10->11->00... (decimal: 0->1->2->3->0...) Errors in this sequence show the loss of data segments.
TX_BYTE_CNT	0 - 7	Number of the valid user data in this data segment. In PROFIBUS-DP, the data segments contain a maximum number of 6 bytes of user data.

10.1.3 SSI-module

Process input data

The field input data is transferred from the connected field device to the BL20-1SSI module.

The process input data is the data that is transferred to the PLC from the BL20-1SSI via a gateway.

This is transferred in an 8 byte format as follows:

- 4 bytes are used for representing the data that was read from the register with the address stated at REG_RD_ADR.
- When necessary, 1 byte represents the register address of the read data and an acknowledgement that the read operation was successful.
- 1 byte can be used to transfer status messages of the SSI encoder. This byte also contains an acknowledgement that the write operation to the register was successful and indication of an active write operation.
- 1 byte contains the results of comparison operations with the SSI encoder value.
- 1 byte contains messages concerning the communication status between the BL20-1SSI module and the SSI encoder, as well as other results of comparison operations.

The following table describes the structure of the 8 x 8 bits of the process input data.

STS (or ERR) contains non-retentive status information, i.e. the bit concerned indicates the actual status.

FLAG describes a retentive flag that is set in the event of a particular event. The bit concerned retains the value until it is reset.

Figure 10-10:
Process input data

Data Image								
Process input data (SSI -> SPS)								
Byte	Bit 7	Bit 6	Bit 5	Bit 4	Bit 3	Bit 2	Bit 1	Bit 0
0	Diagnostic data							
	STS STOP	x	x	ERR PARA	STS UFLW	STS OFLW	ERR SSI	SSI DIAG
1	Status messages							
	STS UP	STS DN	REL CMP2	FLAG CMP2	STS CMP2	REL CMP1	FLAG CMP1	STS CMP2
2	REG WR ACCEPT	REG WR AKN	x	x	SSI STS3	SSI STS2	SSI STS1	SSI STS0
3	REG RD ABORT	x	REG RD ADR (MSB to LSB)					
4	data byte 2							
5	data byte 3							
6	data byte 4							
7	data byte 5							

Table 10-7:
Meaning of the
data bits (process
input)

Designation	Value	Meaning
REG_RD_DATA	0... 2 ³² -1	Content of the register to be read if REG_RD_ABORT = 0. If REG_RD_ABORT = 1, then REG_RD_DATA = 0.
REG_RD_ABORT	0	The reading of the register stated at REG_RD_ADR was accepted and executed. The content of the register is located in the user data range (REG_RD_DATA Bytes 0-3).
	1	The reading of the register stated at REG_RD_ADR was not accepted. The user data range (REG_RD_DATA Bytes 0-3) is zero.
REG_RD_ADR	0...63	The reading of the register stated at REG_RD_ADR was not accepted. The user data range (REG_RD_DATA Bytes 0-3) is zero.
REG_WR_ACCEPT	0	The writing of user data for process output to the register with the address stated at REG_WR_ADR in the process output data could not be executed.
	1	The writing of user process output data to the register with the address stated at REG_WR_ADR in the process output data was successfully completed.
REG_WR_AKN	0	No modification of the data in the register bank by process output, i.e. REG_WR = 0. A write job would be accepted with the next telegram of process output data. (handshake for data transmission to the register.)
	1	A modification of the register contents by a process output was initiated, i.e. REG_WR = 1. A write job would not be accepted with the next telegram of process output data.
SSI_STS3	0	These four bits transfer the status bits of the SSI encoder with the status messages of the SSI module. With some SSI encoders, the status bits are transferred together with the position value.
	1	
SSI_STS2	0	
	1	
SSI_STS1	0	
	1	
SSI_STS0	0	
	1	
STS_UP (LED UP)	0	The SSI encoder values are decremented or the values are constant.
	1	The SSI encoder values are incremented.
STS_DN (LED DN)	0	The SSI encoder values are incremented or the values are constant.
	1	The SSI encoder values are decremented.

Designation	Value	Meaning
REL_CMP2	0	A comparison of the register contents has produced the following result: $(REG_SSI_POS) < (REG_CMP2)$
	1	A comparison of the register contents has produced the following result: $(REG_SSI_POS) \geq (REG_CMP2)$
FLAG_CMP2	0	Default status, i.e. the register contents have not yet matched $(REG_SSI_POS) = (REG_CMP2)$ since the last reset.
	1	The contents of the registers match $(REG_SSI_POS) = (REG_CMP2)$. This marker must be reset with $CLR_CMP2 = 1$ in the process output data.
STS_CMP2	0	A comparison of the register contents has produced the following result: $(REG_SSI_POS) \neq (REG_CMP2)$
	1	A comparison of the register contents has produced the following result: $(REG_SSI_POS) = (REG_CMP2)$
REL_CMP1	0	A comparison of the register contents has produced the following result: $(REG_SSI_POS) < (REG_CMP1)$
	1	A comparison of the register contents has produced the following result: $(REG_SSI_POS) \geq (REG_CMP1)$
FLAG_CMP1	0	Default status, i.e. the register contents have not yet matched $(REG_SSI_POS) = (REG_CMP1)$ since the last reset.
	1	The contents of the registers match: $(REG_SSI_POS) = (REG_CMP1)$. This marker must be reset when $CLR_CMP1 = 1$ in the process output data.
STS_CMP1	0	A comparison of the register contents has produced the following result: $(REG_SSI_POS) \neq (REG_CMP1)$
	1	A comparison of the register contents has produced the following result: $(REG_SSI_POS) = (REG_CMP1)$
STS_STOP	0	The SSI encoder is read cyclically.
	1	Communication with the SSI encoder is stopped as $STOP = 1$ (process output) or $ERR_PARA = 1$.
ERR_PARA	0	The parameter set of the module has been accepted.
	1	Operation of the module is not possible with the present parameter set.
STS_UFLW	0	A comparison of the register contents has produced the following result: $(REG_SSI_POS) \geq (REG_LOWER_LIMIT)$
	1	A comparison of the register contents has produced the following result: $(REG_SSI_POS) < (REG_LOWER_LIMIT)$

Designation	Value	Meaning
STS_OFLW	0	A comparison of the register contents has produced the following result: (REG_SSI_POS) ≤ (REG_UPPER_LIMIT)
	1	A comparison of the register contents has produced the following result: (REG_SSI_POS) > (REG_UPPER_LIMIT)
ERR_SSI	0	SSI encoder signal present.
	1	SSI encoder signal faulty. (e.g. due to a cable break).
SSI_DIAG	0	No enabled status signal is active (SSI_STSx = 0).
	1	At least one enabled status signal is active (SSI_STSx = 1).

Process output data (PDout)

The field output data is transferred from the BL20-1SSI module to the connected field device.

The process output data is the data that is output from the PLC to the BL20-1SSI module via a gateway.

This is transferred in an 8 byte format as follows:

- 4 bytes are used for representing the data that is to be written to the register with the address specified at REG_WR_DATA.
- 1 byte contains the register address for the data that is to be read with the next response telegram.
- 1 byte contains the register address of the data to be written to bytes 0 to 3 of this telegram and a write request.
- 1 byte is used for controlling the comparison operations.
- 1 byte contains a Stop bit for interrupting communication with the encoder.

Figure 10-11:
Process output data

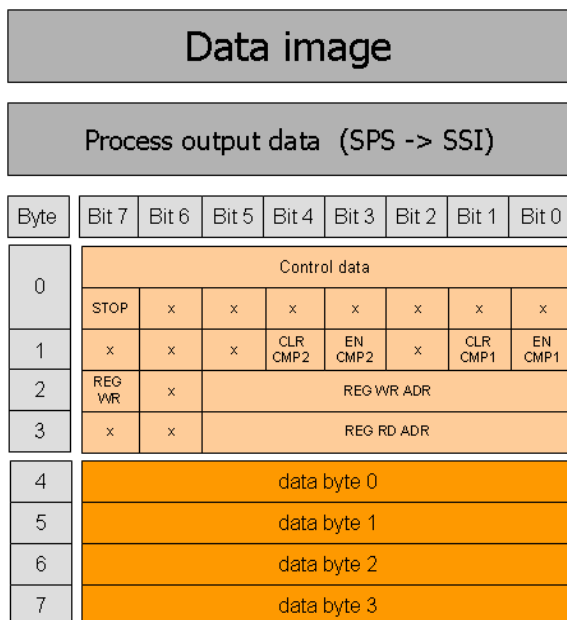

Table 10-8:
Meaning of the
data bits (process
output)

Designation	Value	Meaning
REG_WR_DATA	0... $2^{32}-1$	Value to be written to the register with the address stated at REG_WR_ADR.
REG_RD_ADR	0...63	Address of the register to be read. If the read operation is successful (REG_RD_ABORT = 0), the user data is located in REG_RD_DATA of the process input data (bytes 4 – 7).
REG_WR	0	Default status, i.e. there is no request to overwrite the content of the register with the address stated at REG_WR_ADR with REG_WR_DATA. Bit REG_WR_AKN is reset (0) if necessary.
	1	Request to overwrite the content of the register with the address stated at REG_WR_ADR with REG_WR_DATA.
REG_WR_ADR	0...63	Address of the register to be written with REG_WR_DATA.
CLR_CMP2	0	Default status, i.e. no reset of FLAG_CMP2 active.
	1	Reset of FLAG_CMP2 active
EN_CMP2	0	Default status, i.e. the data bits REL_CMP2, STS_CMP2 and FLAG_CMP2 always have the value 0, irrespective of the actual SSI encoder value.
	1	Comparison active, i.e. the data bits REL_CMP2, STS_CMP2 and FLAG_CMP2 have a value based on the result of the comparison with the SSI encoder value.
CLR_CMP1	0	Default status, i.e. reset of FLAG_CMP1 not active.
	1	Reset of FLAG_CMP1 active
EN_CMP1	0	Default status, i.e. the data bits REL_CMP1, STS_CMP1 and FLAG_CMP1 always have the value 0, irrespective of the actual SSI encoder value.
	1	Comparison active, i.e. the data bits REL_CMP1, STS_CMP1 and FLAG_CMP1 have a value based on the result of the comparison with the SSI encoder value.
STOP	0	Request to read the SSI encoder cyclically
	1	Request to interrupt communication with the encoder

10.2 Nominal current consumption and power loss

Table 10-9:
Nominal current
consumption of
the BL20
modules from
supply terminal
 I_{EL}

Modules	Power supply	Nominal current consumption
Gateway		–
BL20-BR-24VDC-D	10 A	
BL20-PF-24VDC-D	10 A	
BL20-PF-120/230VAC-D	10 A	
BL20-2DI-24VDC-P		≤ 20 mA
BL20-2DI-24VDC-N		≤ 20 mA
BL20-2DI-120/230VAC		≤ 20 mA
BL20-4DI-24VDC-P		≤ 40 mA
BL20-4DI-24VDC-N		≤ 40 mA
BL20-16DI-24VDC-P		≤ 40 mA
BL20-32DI-24VDC-P		≤ 30 mA
BL20-1AI-I(0/4..20MA)		≤ 50 mA
BL20-2AI-I(0/4..20MA)		≤ 12mA
BL20-1AI-U(-10/0..+10VDC)		≤ 50 mA
BL20-2AI-U(-10/0..+10VDC)		≤ 12 mA
BL20-2AI-PT/NI-2/3		< 30 mA
BL20-2AI-THERMO-PI		< 30 mA
BL20-2DO-24VDC-0.5A-P		20 mA (when load current = 0)
BL20-2DO-24VDC-0.5A-N		20 mA (when load current = 0)

Modules	Power supply	Nominal current consumption
BL20-2DO-24VDC-2A-P		< 50 mA (when load current = 0)
BL20-4DO-24VDC-0.5A-P		≤ 25 mA (when load current = 0)
BL20-16DO-24VDC-0.5A-P		< 30 mA
BL20-2DO-120/230VAC-0.5A		< 20 mA (when load current = 0)
BL20-1AO-I(0/4..20MA)		≤ 50 mA
BL20-2AO-I(0/4..20MA)		≤ 50 mA
BL20-2AO-U(-10/0..+10VDC)		≤ 50 mA
BL20-2DO-R-NC		< 20 mA
BL20-2DO-R-NO		< 20 mA
BL20-2DO-R-CO		< 20 mA
BL20-1CNT-24VDC		< 50 mA (when load current = 0)
BL20-2RFID-A		< 100 mA (when load current = 0)

*Table 10-10:
Nominal current
of the BL20
modules on the
module bus*

Modules	Power supply	Nominal current consumption
Gateway		≤ 250 mA
BL20-BR-24VDC-D	1 500 mA	
BL20-PF-24VDC-D		≤ 28 mA
BL20-PF-120/230VAC-D		≤ 25 mA
BL20-2DI-24VDC-P		≤ 28 mA
BL20-2DI-24VDC-N		≤ 28 mA
BL20-2DI-120/230VAC		≤ 28 mA
BL20-4DI-24VDC-P		≤ 29 mA
BL20-4DI-24VDC-N		≤ 28 mA
BL20-16DI-24VDC-P		≤ 45 mA
BL20-32DI-24VDC-P		≤ 30 mA
BL20-1AI-I(0/4...20MA)		≤ 41 mA
BL20-2AI-I(0/4...20MA)		≤ 35 mA
BL20-1AI-U(-10/0...+10VDC)		≤ 41 mA
BL20-2AI-U(-10/0...+10VDC)		≤ 35 mA
BL20-2AI-PT/NI-2/3		≤ 45 mA
BL20-2AI-THERMO-PI		≤ 45 mA
BL20-2DO-24VDC-0.5A-P		≤ 32 mA
BL20-2DO-24VDC-0.5A-N		≤ 32 mA
BL20-2DO-24VDC-2A-P		≤ 33 mA
BL20-4DO-24VDC-0.5A-P		≤ 30 mA
BL20-16DO-24VDC-0.5A-P		≤ 45 mA

Modules	Power supply	Nominal current consumption
BL20-2DO-120/230VAC-0.5A-P		< 35 mA
BL20-1AO-I(0/4...20MA)		≤ 39 mA
BL20-2AO-I(0/4...20MA)		≤ 40 mA
BL20-2AO-U(-10/0...+10VDC)		≤ 43 mA
BL20-2DO-R-NC		≤ 28 mA
BL20-2DO-R-NO		≤ 28 mA
BL20-2DO-R-CO		≤ 28 mA
BL20-1CNT-24VDC		≤ 40 mA
BL20-2RFID-A		30 mA
BL20-E-1SWIRE		60 mA

10.3 Power loss of the modules

<i>Table 10-11: Power loss of the BL20 modules</i>	Modules	Power loss (typical)
	Gateway	–
	BL20-BR-24VDC-D	–
	BL20-PF-24VDC-D	–
	BL20-PF-120/230VAC-D	–
	BL20-2DI-24VDC-P	0.7 W
	BL20-2DI-24VDC-N	0.7 W
	BL20-2DI-120/230VAC	< 1 W
	BL20-4DI-24VDC-P	< 1 W
	BL20-4DI-24VDC-N	< 1 W
	BL20-16DI-24VDC-P	< 2.5 W
	BL20-32DI-24VDC-P	< 4.2 W
	BL20-1AI-I(0/4..20MA)	< 1 W
	BL20-2AI-I(0/4..20MA)	< 1 W
	BL20-1AI-U(-10/0..+10VDC)	< 1 W
	BL20-2AI-U(-10/0..+10VDC)	< 1 W
	BL20-2AI-PT/NI-2/3	< 1 W
	BL20-2AI-THERMO-PI	1 W
	BL20-2DO-24VDC-0.5A-P	1 W
	BL20-2DO-24VDC-0.5A-N	1 W
	BL20-2DO-24VDC-2A-P	1 W
	BL20-4DO-24VDC-0.5A-P	< 1 W
	BL20-16DO-24VDC-0.5A-P	< 4 W
	BL20-2DO-120/230VAC-0.5A	< 1 W
	BL20-1AO-I(0/4..20MA)	< 1 W
	BL20-2AO-I(0/4..20MA)	< 1 W
	BL20-2AO-U(-10/0..+10VDC)	< 1 W
	BL20-2DO-R-NC	1 W
	BL20-2DO-R-NO	1 W
	BL20-2DO-R-CO	1 W
	BL20-1CNT-24VDC	1.3 W

10 Glossary

A**Acknowledge**

Acknowledgment of a signal received.

Active metal component

Conductor or conducting component that is electrically live during operation.

Address

Identification number of, e.g. a memory position, a system or a module within a network.

Addressing

Allocation or setting of an address, e. g. for a module in a network.

ARP

Used to definitely allocate the hardware addresses (MAC-IDs) assigned worldwide to the IP addresses of the network clients via internal tables.

Analog

Infinitely variable value, e. g. voltage. The value of an analog signal can take on any value, within certain limits.

Automation device

A device connected to a technical process with inputs and outputs for control. Programmable logic controllers (PLC) are a special group of automation devices.

B**Baud**

Baud is a measure for the transmission speed of data. 1 Baud corresponds to the transmission of one bit per second (bit/s).

Baud rate

Unit of measurement for measuring data transmission speeds in bit/s.

Bidirectional

Working in both directions.

Bonding strap

Flexible conductor, normally braided, that joins inactive components, e. g. the door of a switchgear cabinet to the cabinet main body.

Bus

Bus system for data exchange, e. g. between CPU, memory and I/O levels. A bus can consist of several parallel cables for data transmission, addressing, control and power supply.

Bus cycle time

Time required for a master to serve all slaves or stations in a bus system, i. e. reading inputs and writing outputs.

Bus line

Smallest unit connected to a bus, consisting of a PLC, a coupling element for modules on the bus and a module.

Bus system

All units which communicate with one another via a bus.

C Capacitive coupling

Electrical capacitive couplings occur between cables with different potentials. Typical sources of interference are, for example, parallel-routed signal cables, contactors and electrostatic discharges.

Check-back interface

The check-back interface is the interface from the counter module to the internal module bus. The bits and bytes are converted by the gateway from the respective type of communication applicable to the fieldbus in to the module-specific bits and bytes.

Coding elements

Two-piece element for the unambiguous assignment of electronic and base modules.

Configuration

Systematic arrangement of the I/O-modules of a station.

Control interface

The control interface is the interface from the internal module bus to the counter module. The commands and signals directed to the counter module are converted by the gateway from the respective type of communication applicable to the fieldbus in to the module-specific bits and bytes.

CPU

Central Processing Unit. Central unit for electronic data processing, the processing core of the PC.

D DHCP

Client-Server-protocol which reduces the effort of assigning IP addresses or other parameters. Serves for dynamic and automatic configuration of devices.

Digital

A value (e. g. a voltage) which can adopt only certain statuses within a finite set, mostly defined as 0 and 1.

DIN

German acronym for German Industrial Standard.

E EIA

Electronic Industries Association – association of electrical companies in the United States.

Electrical components

All objects that produce, convert, transmit, distribute or utilize electrical power (e. g. conductors, cable, machines, control devices).

EMC

Electromagnetic compatibility – the ability of an electrical part to operate in a specific environment without fault and without exerting a negative influence on its environment.

EN

German acronym for European Standard.

ESD

Electrostatic Discharge.

F**Field power supply**

Voltage supply for devices in the field as well as the signal voltage.

Fieldbus

Data network on sensor/actuator level. A fieldbus connects the equipment on the field level. Characteristics of a fieldbus are a high transmission security and real-time behavior.

Force Mode

Software mode which enables the user to set his plant to a required state by forcing certain variables on the input and output modules.

G**GND**

Abbreviation of ground (potential "0").

Ground

Expression used in electrical engineering to describe an area whose electrical potential is equal to zero at any given point. In neutral grounding devices, the potential is not necessarily zero, and one speaks of the ground reference.

Ground connection

One or more components that have a good and direct contact to earth.

Ground reference

Potential of ground in a neutral grounding device. Unlike earth whose potential is always zero, it may have a potential other than zero.

H**Hexadecimal**

System of representing numbers in base 16 with the digits 0... 9, and further with the letters A, B, C, D, E and F.

Hysteresis

A sensor can get caught up at a certain point, and then "waver" at this position. This condition results in the counter content fluctuating around a given value. Should a reference value be within this fluctuating range, then the relevant output would be turned on and off in rhythm with the fluctuating signal.

I**I/O**

Input/output.

Impedance

Total effective resistance that a component or circuit has for an alternating current at a specific frequency.

Inactive metal components

Conductive components that cannot be touched and are electrically isolated from active metal components by insulation, but can adopt voltage in the event of a fault.

Inductive coupling

Magnetic inductive couplings occur between two cables through which an electrical current is flowing. The magnetic effect caused by the electrical currents induces an interference voltage. Typical sources of interference are for example, transformers, motors, parallel-routed network and HF signal cables.

Intelligent modules

Intelligent modules are modules with an internal memory, able to transmit certain commands (e. g. substitute values and others).

IP

Abbreviation for Internet-Protocol, protocol for the packet-oriented and connectionless transport of data packets from a transmitter to a receiver crossing different networks.

L

Lightning protection

All measures taken to protect a system from damage due to overvoltages caused by lightning strike.

Low impedance connection

Connection with a low AC impedance.

LSB

Least Significant bit

M

Mass

All interconnected inactive components that do not take on a dangerous touch potential in the case of a fault.

Master

Station in a bus system that controls the communication between the other stations.

Module bus

The module bus is the internal bus in a station. The modules communicate with the gateway via the module bus which is independent of the fieldbus.

MSB

Most Significant bit

P

Ping

Implementation of an echo-protocol, used for testing whether a particular host is operating properly and is reachable on the network from the testing host.

PLC

Programmable Logic Controller.

Potential compensation

The alignment of electrical levels of electrical components and external conductive components by means of an electrical connection.

Potential free

Galvanic isolation of the reference potentials in I/O-modules of the control and load circuits.

Potential linked

Electrical connection of the reference potentials in I/O-modules of the control and load circuits.

Protective earth

Electrical conductor for protection against dangerous shock currents. Generally represented by PE (protective earth).

R**Radiation coupling**

A radiation coupling appears when an electromagnetic wave hits a conductive structure. Voltages and currents are induced by the collision. Typical sources of interference are for example, sparking gaps (spark plugs, commutators from electric motors) and transmitters (e. g. radio), that are operated near to conducting structures.

Reaction time

The time required in a bus system between a reading operation being sent and the receipt of an answer. It is the time required by an input module to change a signal at its input until the signal is sent to the bus system.

Reference potential

Potential from which all voltages of connected circuits are viewed and/or measured.

Repeater

Amplifier for signals transmitted via a bus.

Root-connecting

Creating a new potential group using a power distribution module. This allows sensors and loads to be supplied individually.

RS 485

Serial interface in accordance with EIA standards, for fast data transmission via multiple transmitters.

S**Serial**

Type of information transmission, by which data is transmitted bit by bit via a cable.

Setting parameters

Setting parameters of individual stations on the bus and their modules in the configuration software of the master.

Shield

Conductive screen of cables, enclosures and cabinets.

Shielding

Description of all measures and devices used to join installation components to the shield.

Short-circuit proof

Characteristic of electrical components. A short-circuit proof part withstands thermal and dynamic loads which can occur at its place of installation due to a short circuit.

Station

A functional unit or I/O components consisting of a number of elements.

T

TCP

Abbreviation for Transmission Control Protocol, connection-oriented transport protocol within the Internet protocol suite. Certain error detection mechanisms (i.e. acknowledgements, time-out monitoring) can guarantee a safe and error free data transport.

Terminating resistance

Resistor on both ends of a bus cable used to prevent interfering signal reflections and which provides bus cable matching. Terminating resistors must always be the last component at the end of a bus segment.

To ground

Connection of a conductive component with the grounding connection via a grounding installation.

Topology

Geometrical structure of a network or the circuitry arrangement.

U

UDP

Abbreviation for User Datagram Protocol. UDP is an transport protocol for the connectionless data between Ethernet hosts.

Unidirectional

Working in one direction.

11 Index

- A**
- addressing 4-8
 - Analog Input Current Module Class 5-44
 - Analog Input PT100/NI Module Class 5-48
 - Analog Input THERMO Module Class 5-51
 - Analog Input Voltage Module Class 5-40
 - Analog Output Current Module Class 5-46
 - Analog Output Voltage Module Class 5-42
 - APR (Address Resolution Protocol) 3-5
- B**
- base modules 2-5
 - basic concept 2-2
- C**
- classes
 - Assembly Object 5-13
 - Connection Manager Object 5-17
 - Ethernet Link Object 5-23
 - Ethernet/IP standard 5-5
 - Identity Object 5-6
 - Message Router Object 5-8
 - Port Object 5-17
 - process data 5-32
 - RFID modules 5-94
 - TCP/IP Interface Object 5-18
 - VSC-Vendor Specific Classes 5-25
 - communications profile 5-3
 - Consumed Data 5-15
 - Control word 4-23, 5-15, 5-16
 - COS I/O connection 5-3
 - C-rail (cross connection) 7-8
 - Cyclic I/O connection 5-4
- D**
- Data mapping 5-15
 - Digital Input Module Class 5-36
 - Digital Output Module Class 5-38
 - Digital Versatile Module Class 5-82
 - Division 2 9-1
- E**
- earth-free operation 8-6
 - electromagnetic compatibility 8-6
 - electronics modules 2-3
 - electrostatic discharge 8-9
 - EMC 8-6
 - end bracket 2-7
 - end plate 2-6
 - ESD, electrostatic discharge 8-9
 - Ethernet 3-4
 - IP address 3-4
 - MAC-ID 3-4
 - manufacturer identifier 3-4
 - netmask 3-4
 - network classes 3-4
 - subnet ID 3-4
 - explicit messages 5-3
- F**
- firmware download 7-13
 - flexibility 2-2
- G**
- gateway
 - addressing 4-8
 - BOOTP-mode 4-10
 - DHCP-mode 4-11
 - PGM-mode 4-12
 - rotary-mode 4-9, 6-10
 - structure 4-4
 - technical data 4-4
 - gateways 2-3
- I**
- I/O messages 5-3
 - inductive loads, protective circuit 8-9
 - input assembly instance 5-14
 - Instance 101 5-14
 - Instance 102 5-14
 - Instance 103 5-14
 - Instance 104 5-14
 - IP (Internet Protocol) 3-3
 - IP address 3-4
 - PC 6-4
- J**
- jumper 2-7
- L**
- labels 2-7
- M**
- markers 2-7
 - mounting rail 8-7
- N**
- network configuration 6-1
 - nominal current consumption 10-22
- O**
- output assembly instance 5-14
- P**
- PE connection 8-6
 - pin assignment
 - power supply 4-6
 - planning 7-2
 - potential groups 7-7
 - potential relationships 8-5

Index

potential-compensation cable	8-9
power distribution	2-3
power loss	10-22
power supply	7-4
Power Supply Module Class	5-34
prescribed use	1-3
process data	5-14
Process input	
–counter, counter mode	10-2
–counter, measurement mode	10-4
–RSxxx	10-13
–SSI	10-17
Process output	
–counter, counter mode	10-6
–counter, measurement mode	10-10
–RSxxx	10-15
–SSI	10-20
Produced Data	5-15
protection class IP20	2-2
R	
RFID-S module class	5-94
RS232 Module Class	5-60
RS485/422 Module Class	5-67
RSLinx	6-13
S	
service interface	4-6
shield connection	
–analog modules	2-9
shielding	8-8
SSI Module Class	5-74
status information	5-14
Status word	4-23, 5-15, 5-16
symbols	1-4
T	
TCP (Transmission Control Protocol)	3-3
TCP/IP host	3-4
Terminal Slot Class	5-28
transport, appropriate	1-3
U	
UCMM	5-4
V	
VSC-Vendor Specific Classes	5-25
W	
WIN 2000	6-4
WIN NT	6-5
WIN XP	6-4
Z	
Zone 2	9-1

TURCK

Industrial
Automation



www.turck.com

Hans Turck GmbH & Co. KG
45472 Mülheim an der Ruhr
Germany
Witzlebenstraße 7
Tel. +49 (0) 208 4952-0
Fax +49 (0) 208 4952-264
E-Mail more@turck.com
Internet www.turck.com

D301034 1211